

AB



BIDIRECTIONAL WAFER KNIFE GATE VALVE

DESCRIPTION

- Bidirectional wafer-design knife gate valve.
- One-piece cast body.
- Provides high flow rates with low pressure drop.
- Various seat and packing materials available.
- Face-to-face dimension in accordance with CMO standard.

GENERAL APPLICATIONS

This knife gate valve is suitable for liquids that contain a maximum of 4% suspended solids.

Designed for applications such as:

- Chemical plants
- Pumping
- Food Industry
- Sewage treatment

In all these applications, the valve should be installed once the fluid has been filtered, to eliminate solids or large particles it contains.

SIZES

ND50 a ND600.

** Others ND on request*

WORKING PRESSURE: (ΔP)

ND50-ND150	10 bar
ND200	8 bar
ND250-ND300	6 bar
ND350-ND450	5 bar
ND450-ND600	3 bar

** Other pressures, upon request.*

The indicated working pressures are valid both ways..

FLANGES

- DIN PN10 and ANSI B16.5 (class 150)

OTHER COMMON

- DIN PN 6
- DIN PN 16
- DIN PN25 BS "D" AND "E"
- ANSI 150
- Others on request:

** Others on request.*



Fig. 1

DIRECTIVES

- Pressure Equipment Directive: **(PED) ART 4.3 /CAT.1.**
- Potential Explosive Atmospheres Directive: **(ATEX) CAT.3 ZONA 2 y 22 GD.**

** For further information on categories and zones please contact the **CMO VALVES**. Technical-Commercial Dept.*

QUALITY DOSSIER

All valves are tested hydrostatically at CMO and material and test certificates can be provided.

- Body test = working pressure x 1.5.
- Seat test = working pressure x 1.1.

ADVANTAGES

This valve's main characteristic is the body design. It is a one-piece machined cast body with wedges on both sides that offers the ability to work with fluids in both directions with the same pressure.

The sealing joint has a stainless steel ring that ensures that the inside of the body is kept clean and prevents the joint from coming loose. This design provides a completely flat seat with no internal cavities and avoids any build up of solids in the seat area.

The stem protection hood is independent from the handwheel securing nut, this means the hood can be disassembled without the need to release the handwheel. This advantage allows regular maintenance operations to be performed, such as lubricating the stem...

The stem on the valve is made of 18/8 stainless steel. This is another added advantage, as some manufacturers produce it with 13% chrome and it gets rusty very quickly. The handwheel is made of GJS-500 nodular cast iron. Some manufacturers produce them in normal cast iron which can lead to breakages in the event of very high operating torque or knocks.

The yoke is has a compact design with the bronze actuator nut protected in a sealed and lubricated box. This makes it possible to move the valve with a key, even without the handwheel (in other manufacturers' products this is not possible).

The pneumatic actuator's upper and lower covers are made of GJS-400 nodular cast iron, making them highly shock resistant. This characteristic is essential in pneumatic actuators.

The pneumatic cylinder's o-ring seals are commercial products and can be purchased worldwide. This means it is not necessary to contact **CMO Valves** every time a seal is required.

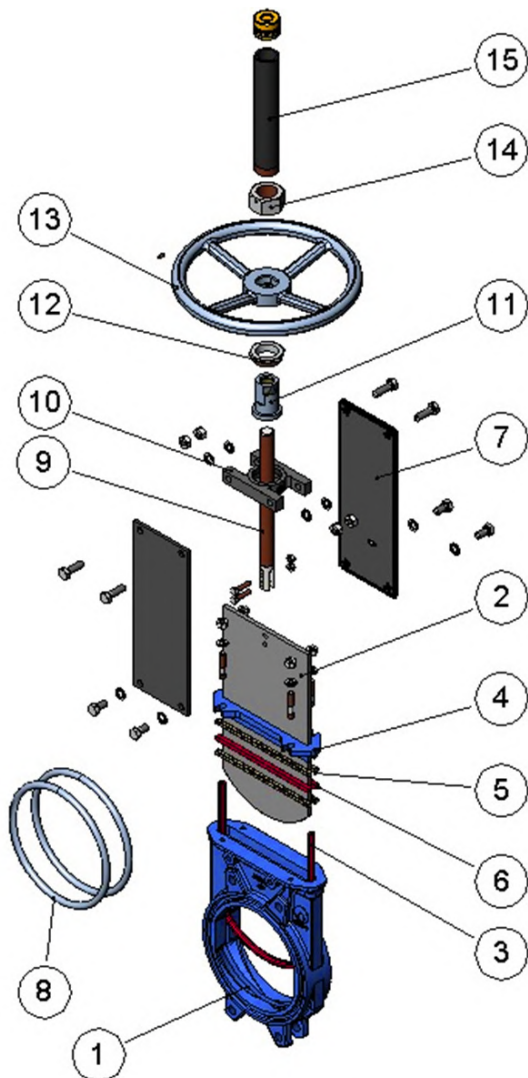

Fig. 2

STANDARD COMPONENTS LIST

COMPONENT	CAST IRON VERSION	STAINLESS STEEL
1 BODY	GJL-250	CF8M
2 GATE	AISI304	AISI316
3 SEAT	EPDM	
4 PACKING GLAND	GJS-500	CF8M
5 PACKING	SYNT + PTFE	
6 O-RING SEAL	EPDM	
7 SUPPORT PLATES	S275JR	
8 O-RING	NITRILE	
9 STEM	AISI303	
10 YOKE	STEEL	
11 STEM NUT	BRONZE	
12 CHECK NUT	ST44.2 + ZINC	
13 HANDWHEEL	NODULAR CAST IRON	
14 NUT	STEEL	
15 HOOD	STEEL	

Table. 1

DESIGN CHARACTERISTICS

BODY

- Bidirectional wafer-design knife gate valve. One-piece cast iron body.
- Full port designed to provide high flow rates with low pressure drop.
- The body's internal design prevents any build up of solids in the seat area.
- The standard manufacturing materials are GJL-250 cast iron and CF8M stainless steel. Other materials, such as GJS-500 nodular cast iron, A216WCB carbon steel and stainless steel alloys (AISI316Ti, Duplex, 254SMO, Uranus B6...) are available on request. As standard, iron or carbon steel valves are painted with an anti-corrosive protection of 80 microns of EPOXY (colour RAL 5015). Other types of anti-corrosive protections are available on request.

GATE

The standard manufacturing materials are AISI304 stainless steel in valves with iron body and AISI316 stainless steel in valves with CF8M body. Other materials or combinations can be supplied on request.

The gate is polished on both sides to provide a smooth contact surface with the resilient seat. At the same time, the gate is rounded to prevent the seat from being cut.

Different degrees of polishing, anti-abrasion treatments and modifications are available to adapt the valves to the customer's requirements.

RESILIENT SEAT MATERIALS

EPDM

This is the standard resilient seat fitted on **CMO valves**. It can be used in many applications, however, it is generally used for water and products diluted in water at temperatures no higher than 90°C*. It can also be used with abrasive products and it provides the valve with 100% watertight integrity.

NITRILE

It is used in fluids containing fats or oils at temperatures no higher than 90°C*. It provides the valve with 100% watertight integrity.

FPM

Suitable for corrosive applications and continuous high temperatures of up to 190°C and peaks of 210°C. It provides the valve with 100% watertight integrity.

SILICONE

Mainly used in the food industry and for pharmaceutical products with temperatures no higher than 200°C. It provides the valve with 100% watertight integrity.

Note: In some applications other types of resilient materials are used, such as hypalon, butile or natural rubber. Please contact us if you require one of these materials

SEAT (watertight)

There is only one seat design available on the AB valve and it must always be soft seated. **It can never have a metal or PTFE sealing joint.**

Below we show the detail of the seat:

The **AB** valve seat is a square rubber joint with an internal stainless steel wire.

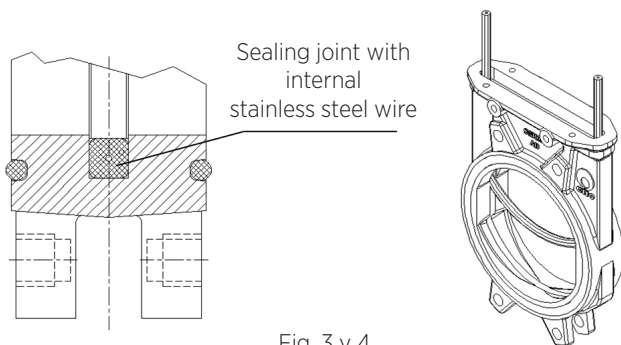

Fig. 3 y 4

This rubber joint is inserted inside the body in such a way that it starts on one side, level with the packing, and continues around the body to reach the other end of the packing area.

This means that the sealing joint is not installed around the whole perimeter of the valve's flow passing hole, but rather, it is installed in a U shape, to cover the gate's perimeter.

The internal stainless steel wire helps to keep the U shape and ensures that the joint does not come out of the body because of the flow as it passes through the valve.

This design provides a completely flat seal with no cavities and avoids any solids being stored in the seal area.

PACKING

The **CMO VALVES** standard packing is composed of three lines with a specially designed EPDM O-ring in the middle which provides watertight integrity between the body and the gate, preventing any type of leakage to the atmosphere.

It is located in an easily accessible place and can be replaced without dismantling the valve from the pipeline.

Below we indicate various types of packing available according to the application in which the valve is located:

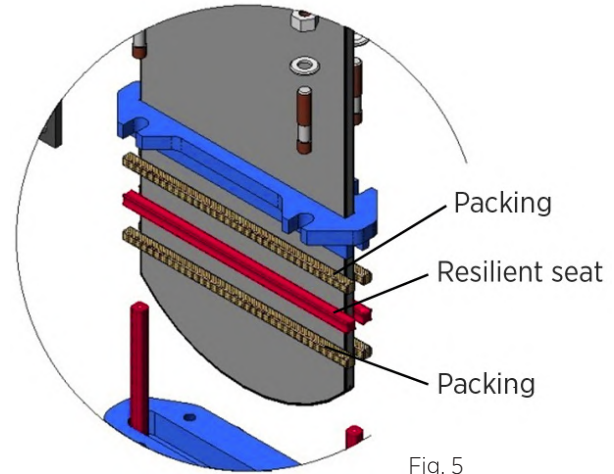

Fig. 5

GREASED COTTON (Recommended for hydraulic services):

This packing is composed of braided cotton fibres soaked in grease both inside and out. It is for general use in hydraulic applications in both pumps and valves.

DRY COTTON

This packing is composed of cotton fibres. It is for general use in hydraulic applications with solids.

COTTON + PTFE

This packing is composed of braided cotton fibres soaked in PTFE both inside and out. It is for general use in hydraulic applications in both pumps and valves.

SINTETICO + PTFE

This packing is composed of braided synthetic fibres soaked in PTFE both inside and out. It is for general use in hydraulic applications in both pumps and valves and in all types of fluids, especially corrosive ones, including concentrated and oxidising oils. It is also used in liquids with solid particles in suspension.

GRAPHITE

This packing is composed of high-purity graphite fibres. A diagonal braiding system is used and it is impregnated with graphite and lubricant which helps to reduce porosity and improve operation. It has a wide range of applications as graphite is resistant to steam, water, oils, solvents, alkali and most acids.

CERAMIC FIBRE

This packing is composed of ceramic material fibres. Its main applications are with air or gas at high temperatures and low pressures.

SEAT/SEALS			PACKING			
Material	Max. T. (°C)	Applications	Material	P (bar)	Max. T. (°C)	pH
EPDM (E)	90 *	Mineral acids and oils	Greased cotton	10	100	6-8
Nitrile (N)	90 *	Hydrocarbons, oils and greases	Dry cotton (AS)	0.5	100	6-8
FPM (V)	200	Hydrocarbons and solvents	Synthetic + PTFE	100	-200+270	0-14
Silicone (S)	200	Food Products	Graphite	40	650	0-14
Note: More details and other materials available on request.			Ceramic Fibre	0.3	1400	0-14

* => EPDM and nitrile: is possible until serving temperature Max.: 120°C under request.

Table. 2

STEM

The stem on the **CMO VALVES** valve is made of 18/8 stainless steel. This characteristic provides high resistance and excellent corrosion-resistant properties. The valve design can be rising stem or non-rising stem. When rising stem is required a stem hood is supplied to protect the stem from contact with dust and dirt, as well as keeping it lubricated.

PACKING GLAND

The packing gland allows uniform force and pressure to be applied to the packing to ensure watertight integrity. As standard, valves with cast iron body include GJS-500 packing glands, whilst valves with stainless steel body have CF8M packing glands

ACTUATORS

All types of actuators can be supplied, with the advantage that the design is fully interchangeable. It is not possible to change the levers action. This design allows the customer to change the actuators themselves and normally no extra assembly accessories are required. In the event any accessory is required, **CMO VALVES** will supply it.

Fig. 6

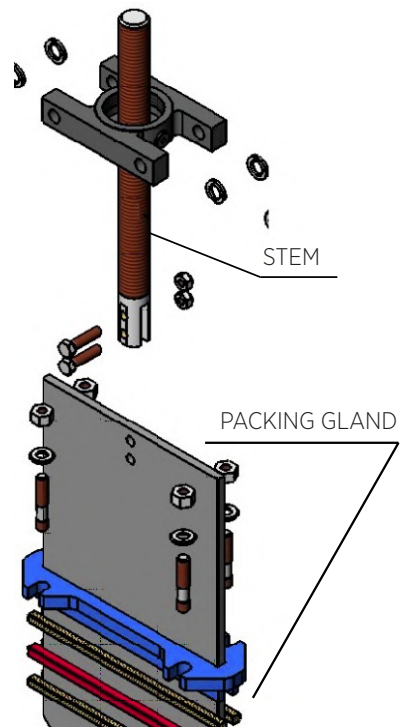

Manual Actuators

Handwheel with rising stem / Non-rising stem

Chainwheel / Lever

Gearbox / Others (square stem, etc)

Automatic Actuators

Electric actuator

Pneumatic cylinder

Hydraulic cylinder

Wide range of accessories available

Mechanical stoppers

Locking devices

Emergency manual actuators

Electrovalves

Positioners

Limit switches

Proximity detectors

Straight floor stand (fig. 5)

Leaning floor stand (fig. 6)

The chainwheel and gear box actuators are also available with non-rising stem. Graphical representation of some actuators on the next page (Fig. 7).

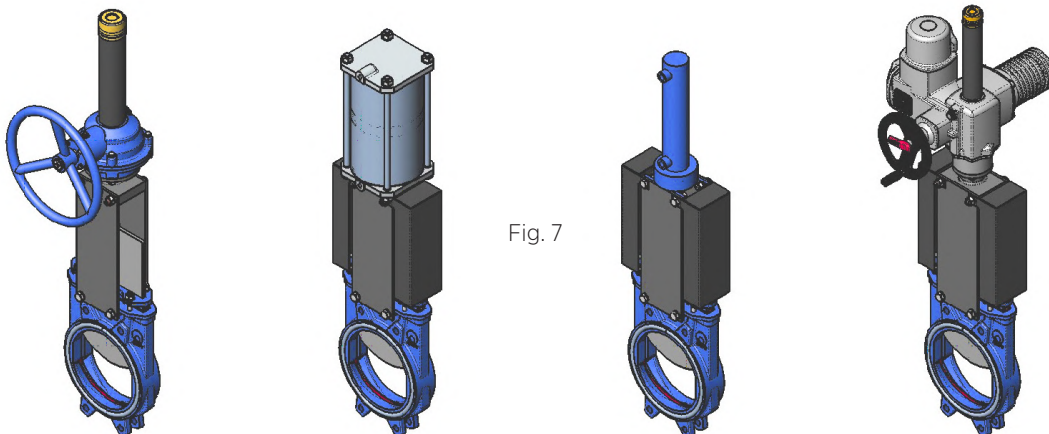

Fig. 7

HANDWHEEL GEAR BOX

PNEUMATIC ACTUATOR

HYDRAULIC ACTUATOR

ELECTRIC-MOTOR

ACCESSORIES AND OPTIONS

Different types of accessories are available to adapt the valve to specific working conditions such as:

MIRROR POLISHED GATE

Recommended for the food industry, its function is to prevent solids from sticking to the gate. They slide off the gate and do not stick to it.

PTFE LINED GATE

As with the mirror polished gate, it improves the valve's resistance to products that can stick to the gate.

STELLITED GATE

Stellite is added to the gate's lower edge to protect it from abrasion.

SCRAPER IN THE PACKING

Its function is to clean the gate during the opening movement and prevent possible damage to the packing.

AIR INJECTION IN THE PACKING GLAND

By injecting air in the packing, an air chamber is created which improves the watertight integrity.

HEATING JACKET

Recomendado en aplicaciones en las que el fluido se puede endurecer y solidificar dentro del cuerpo de la válvula. Una camisa exterior en el cuerpo mantiene constante la temperatura del mismo evitando la solidificación del fluido.

SOPORTE DE ACCIONAMIENTO O PUENTE

Recommended in applications in which the fluid can harden and solidify inside the valve's body. An external jacket keeps the body temperature constant, preventing the fluid from solidifying.

MECHANICAL LIMIT SWITCHES, INDUCTIVE SWITCHES AND POSITIONERS

Indicates the valve's specific or continuous position.

SOLENOID VALVES

For air distribution to pneumatic actuators.

CONNECTION BOXES, WIRING AND PNEUMATIC PIPING

Fully assembled units can be supplied with all the necessary accessories.

STROKE LIMITING MECHANICAL STOPS

They allow mechanical adjustment of the stroke, limiting the valve travel.

MECHANICAL LOCKING DEVICE

Allows the valve to be mechanically locked in a set position for long periods of time.

EMERGENCY MANUAL ACTUATOR (HAND WHEEL /GEAR BOX)

Allows manual operation of the valve in the event of power or air failure.

INSUFFLATIONS IN THE BODY

It is possible to make several holes in the body to blow air, steam or other fluids and thus clean the valve seat before it closes

SOLENOID VALVE

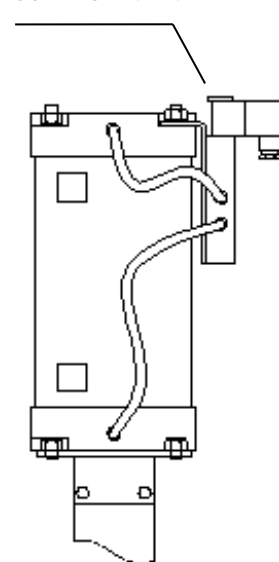
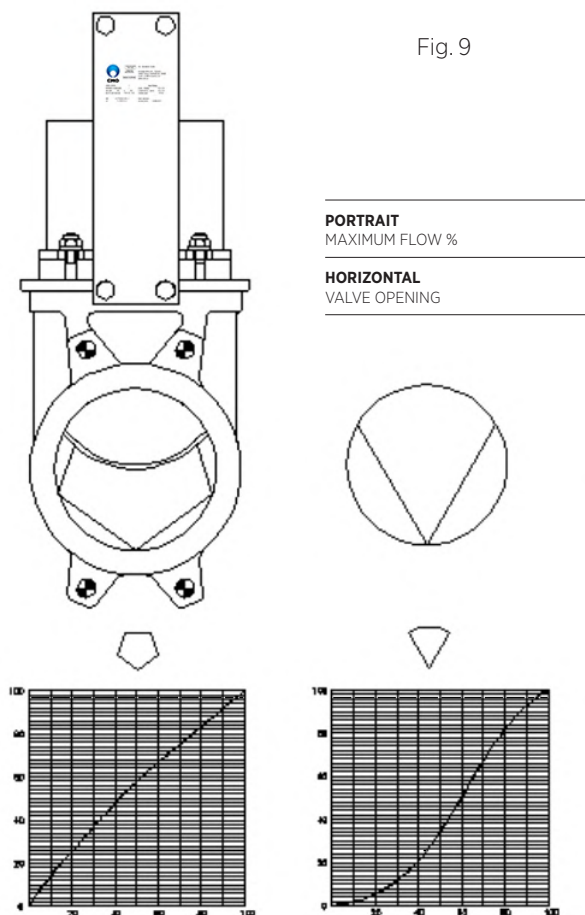

Fig. 8

Fig. 9



TRIANGULAR (V-NOTCH) AND PENTAGONAL DIAPHRAGM WITH INDICATION RULE (Fig. 9)

Recommended for applications in which flow regulation is required. Allows flow control according to the valve's opening percentage.

INTERCHANGEABLE ACTUATORS

All actuators are easily interchangeable, except the lever.

EPOXY COATING

All cast iron and carbon steel bodies and components on **CMO Valves** are EPOXY coated, giving the valves great resistance to corrosion and an excellent finish. **CMO Valves** standard colour is blue, RAL-5015..

GATE SAFETY PROTECTION

In accordance with European Safety Standards ("EC" marking), **CMO Valves** automated valves are equipped with gate guards, to prevent any objects from being accidentally caught in the gate.

BONNET

El bonete proporciona una estanqueidad total hacia el exterior, reduciendo el mantenimiento del prensaestopas.

Fig. 10

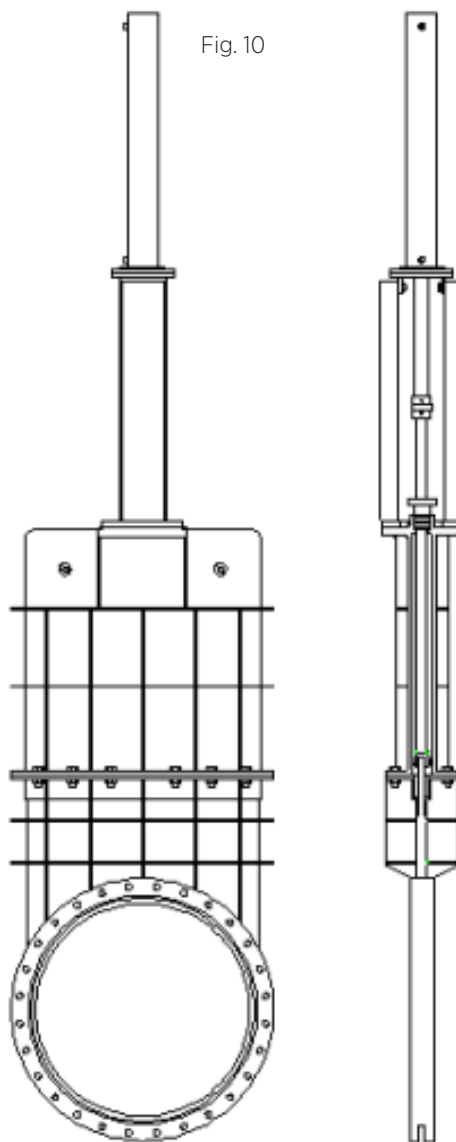

WATERTIGHT SEAL

The joint is fitted into the body, inserted in the seat and in contact with the whole perimeter of the gate which is in contact with the body, this ensures perfect watertight integrity and circulation in both directions, it also prevents build up of solids on the seat making it difficult to seal. The joint contains an internal wire, as can be seen in Fig 11.

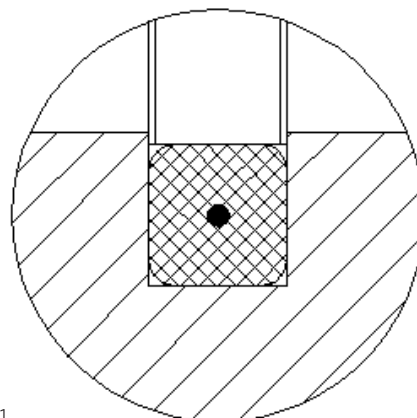

Fig. 11

TYPES OF EXTENSION

If the need is to operate the valve from a remote position, we can place different types of drives:

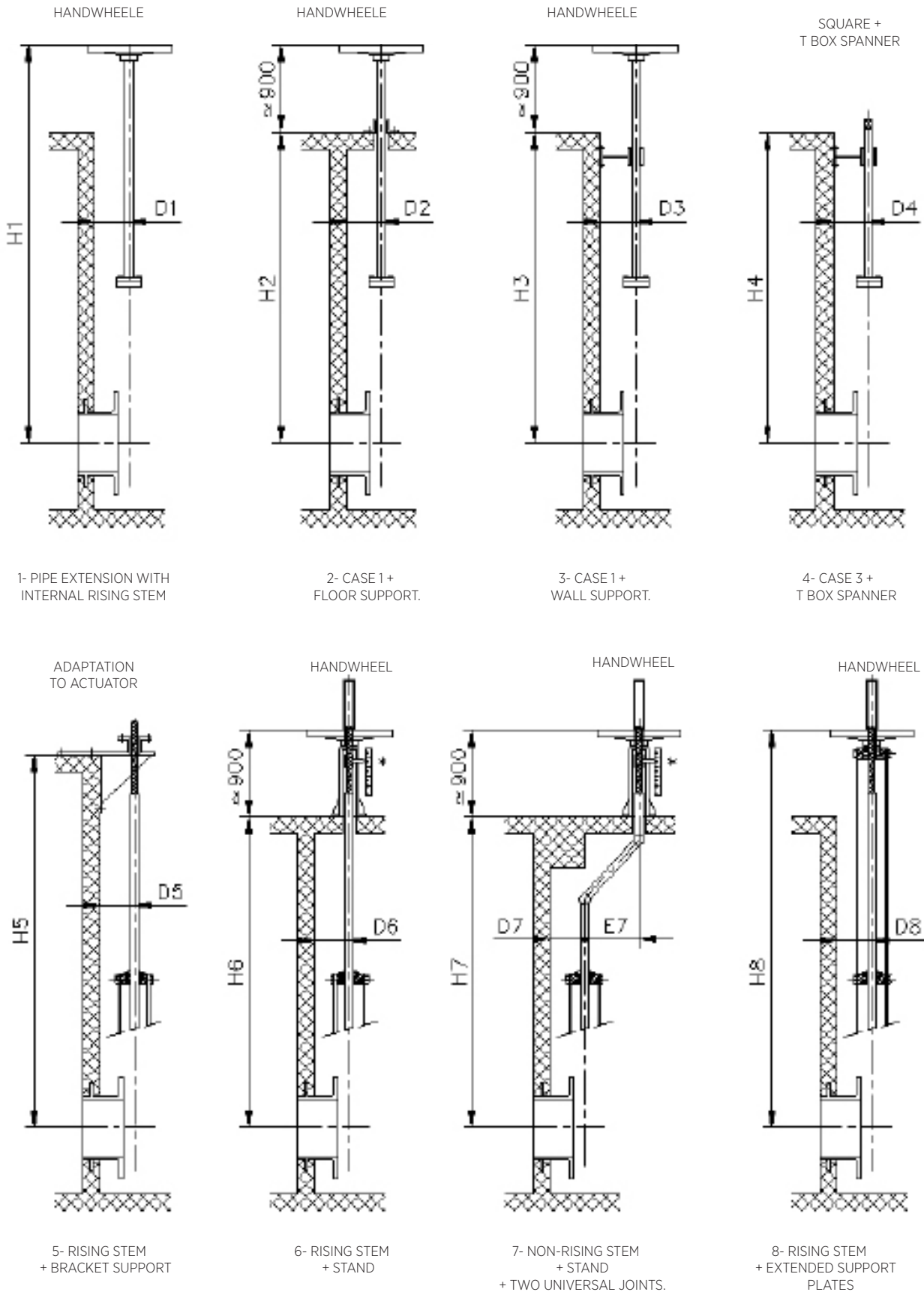

Fig. 12

HANDWHEEL with Rising Stem

OPTIONS

- Locking devices
- Extensions: stand, pipe, plates...
- ND higher than those give in the table

ACTUATOR INCLUDING

- Handwheel
- Stem
- Nut
- Stem protection hood

AVAILABLE

- ND 50 to ND 600.
- From ND600 (inclusive) the actuator has a gearbox
- Other pressures on request.

* Others ND on request.

B = Max. width of the valve (without actuator)

D = Max. height of the valve (without actuator)

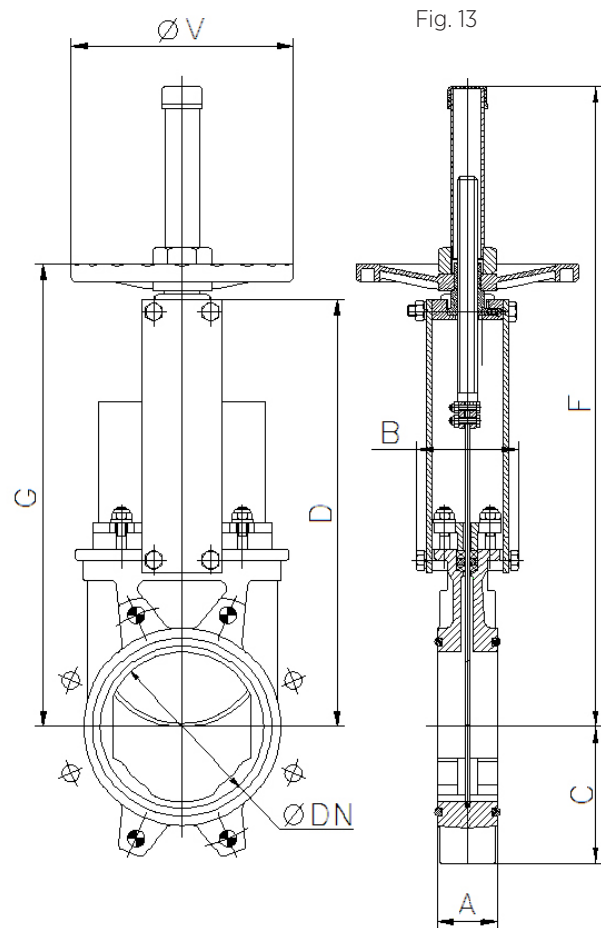

ND	ΔP (bar)	A	B	C	D	F	G	ϕV	Weigth (Kg)
50	10	40	91	61	241	410	280	225	7
65	10	40	91	68	268	437	308	225	8
80	10	50	91	91	294	463	333	225	9
100	10	50	91	104	334	503	373	225	11
125	10	50	101	118	367	586	407	225	13
150	10	60	101	130	419	638	458	225	17
200	8	60	118	159	525	816	578	325	28
250	6	70	118	196	626	1017	679	325	40
300	6	70	118	230	726	1117	779	380	56
350	5	96	290	254	797	1337	906	450	94
400	5	100	290	287	903	1443	1012	450	116
450	3	106	290	304	989	1629	1098	450	162
500	3	110	290	340	1101	1741	1210	450	187
600	3	110	290	398	1307	2047	1416	450	260

Table. 3

HANDWHEEL WITH NON-RISING STEM

Suitable when no size limitations exist.

B = Max. width of the valve (without actuator)

J = Max. height of the valve (without actuator)

OPTIONS

- Square nut
- Locking devices
- Extensions: stand, pipe, plates...
- ND higher than those give in the table

ACTUATOR INCLUDING

- Handwheel
- Stem
- Guide bearings on the yoke.
- Nut

AVAILABLE

- ND 50 to ND 600.
- Other pressures on request.

* Others ND on request.

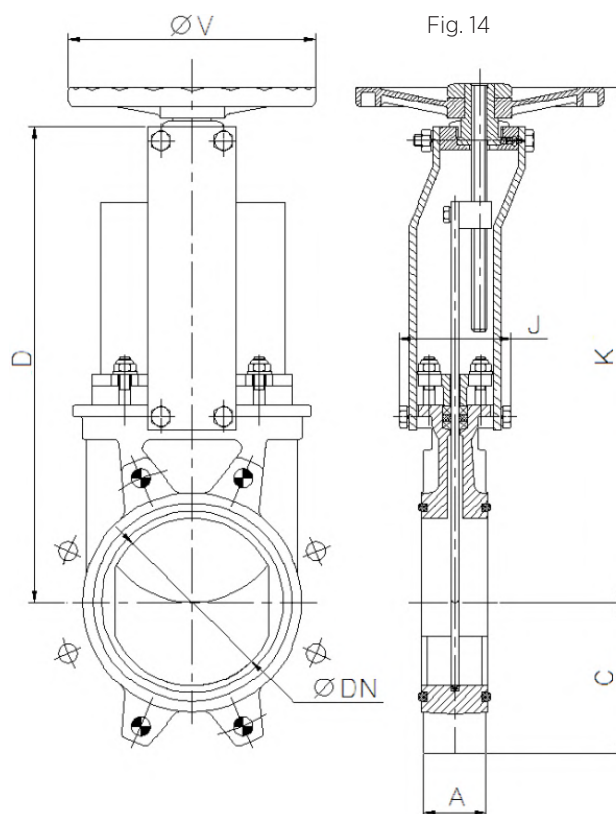

ND	ΔP (bar)	A	C	D	J	K	øV	Weight (Kg)
50	10	40	61	241	101	280	225	7
65	10	40	68	268	101	308	225	8
80	10	50	91	294	101	333	225	9
100	10	50	104	334	101	373	225	11
125	10	50	118	367	111	407	225	13
150	10	60	130	419	111	458	225	17
200	8	60	159	525	128	578	325	28
250	6	70	196	626	128	679	325	40
300	6	70	230	726	128	779	380	56
350	5	96	254	797	305	906	450	94
400	5	100	287	903	305	1012	450	116
450	3	106	304	989	305	1098	450	162
500	3	110	340	1101	305	1210	450	187
600	3	110	398	1307	305	1416	450	260

Table. 4

CHAINWHEEL

Widely used in raised installations with difficult access, the handwheel is fitted in vertical position.

OPTIONS

- Locking devices
- Extensions: stand, pipe, plates...
- Non-rising stem
- ND higher than those give in the table

ACTUATOR INCLUDING

- Handwheel
- Stem
- Nut
- Hood
- Chain

AVAILABLE

- ND 50 to ND 600.
- Other pressures on request.

* Others ND on request.

B = Max. width of the valve (without actuator)

D = Max. height of the valve (without actuator)

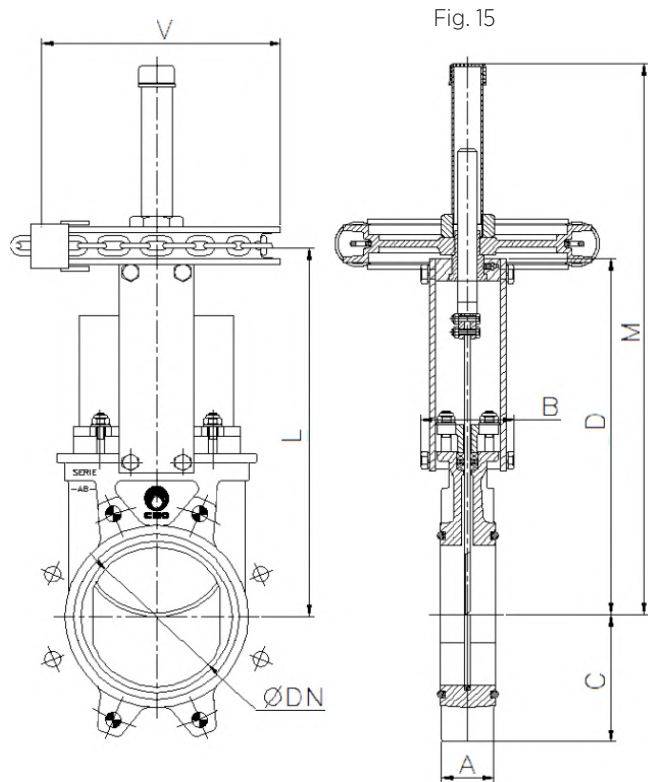

ND	ΔP (bar)	A	B	C	D	L	M	øVc	Weight (Kg)
50	10	40	91	61	241	280	410	225	7
65	10	40	91	68	268	308	437	225	8
80	10	50	91	91	294	333	463	225	9
100	10	50	91	104	334	373	503	225	11
125	10	50	101	118	367	407	586	225	13
150	10	60	101	130	419	458	638	225	17
200	8	60	118	159	525	578	816	300	28
250	6	70	118	196	626	679	1017	300	40
300	6	70	118	230	726	779	1117	300	56
350	5	96	290	254	797	906	1337	402	94
400	5	100	290	287	903	1012	1443	402	116
450	3	106	290	304	989	1098	1629	402	162
500	3	110	290	340	1101	1210	1741	402	187
600	3	110	290	398	1307	1416	2047	402	260

Table. 5

LEVER

It is a fast actuator.

B = Max. width of the valve (without actuator)

D = Max. height of the valve (without actuator)

ACTUATOR INCLUDING

- Lever
- Rod
- Guide bearing
- External limiting switches to maintain the position

AVAILABLE

- ND 50 to ND 200.
- Other pressures on request.

* Others ND on request.

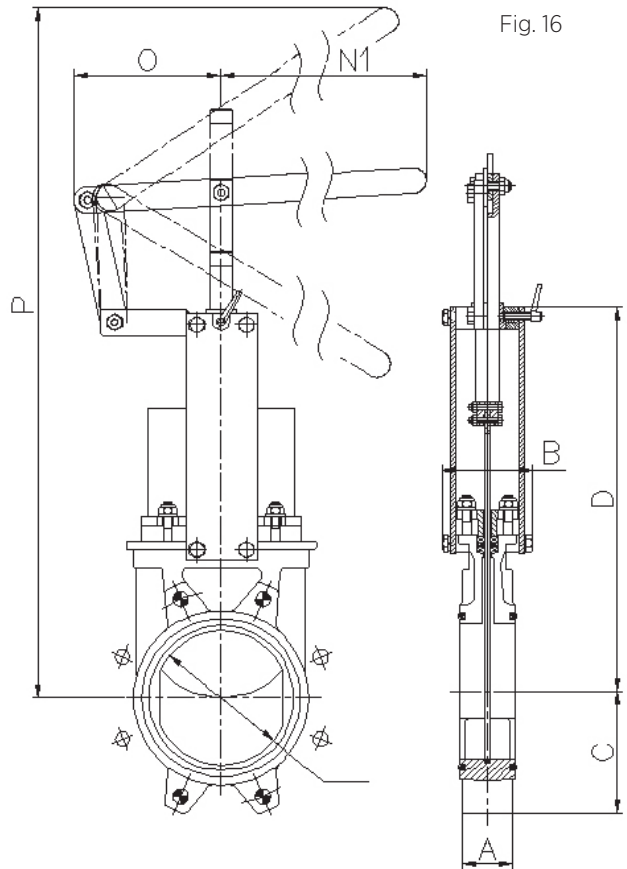

ND	ΔP (bar)	A	B	C	D	N1	O	P	Weight (Kg)
50	10*	40	91	61	241	325	155	504	8
65	10*	40	91	68	268	325	155	526	9
80	10*	50	91	91	294	325	155	549	10
100	10*	50	91	104	334	325	155	605	11
125	10*	50	101	118	367	425	155	902	14
150	10*	60	101	130	419	425	155	956	16
200	8*	60	118	159	525	620	290	1027	32

Table. 6

GEAR BOX

OPTIONS

- Chainwheel
- Extensions: stand, pipe, plates...
- Locking devices
- Non-rising stem

ACTUATOR INCLUDING

- Stem
- Yoke
- Cone-shaped gear box
- Handwheel

AVAILABLE

- ND 50 to ND 600.
- Other pressures on request.
- Standard ratio = 4 to 1 .

* Others ND on request.

B = Max. width of the valve (without actuator)

P = Max. height of the valve (without actuator)

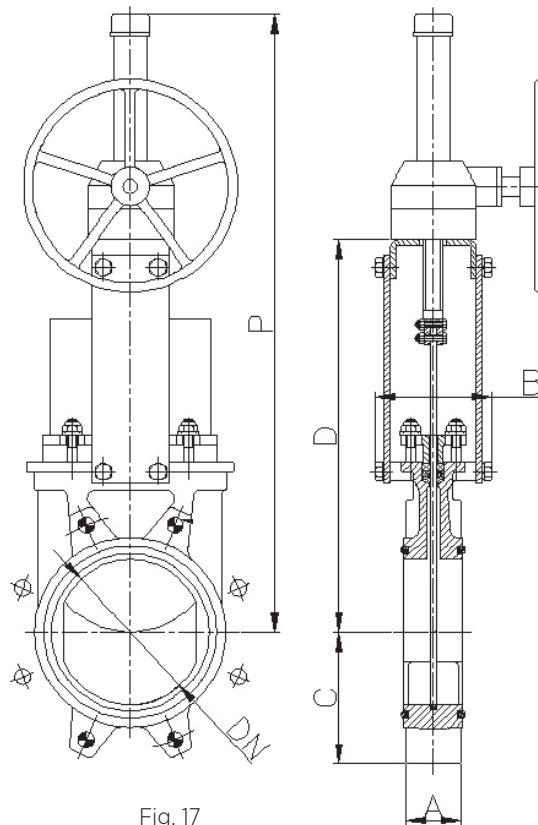

Fig. 17

ND	ΔP (bar)	A	B	C	D	P	Weigth (Kg)
50	10	40	91	61	241	540	20
65	10	40	91	68	268	566	21
80	10	50	91	91	294	592	22
100	10	50	91	104	334	632	24
125	10	50	101	118	367	665	26
150	10	60	101	130	419	717	30
200	8	60	118	159	525	942	41
250	6	70	118	196	626	1033	53
300	6	70	118	230	726	1121	69
350	5	96	290	254	797	1305	107
400	5	100	290	287	903	1403	130
450	3	106	290	304	989	1677	183
500	3	110	290	340	1101	1789	204
600	3	110	290	398	1307	1995	288

Table. 7

DOUBLE-ACTING PNEUMATIC CYLINDER

CMO Valves double-acting pneumatic actuators are designed to work at a pressure between 6 and 10 kg/cm².

10 bar is the maximum admissible air pressure. For air pressures below 6 bar please consult manufacturer.

For ND50 to ND200 valves, the cylinder's jacket and covers are made of aluminium, the rod of AISI304, the piston of rubber-coated steel and the O-ring seals are made of nitrile.

For valves larger than ND200 the covers are made of nodular cast iron or carbon steel.

On request, we can also supply the actuator made entirely of stainless steel, especially for installation in corrosive atmospheres.

AVAILABLE

- DN50 a DN600
- Other pressures on request.

* Others ND on request.

B = Max. width of the valve (without actuator)

D = Max. height of the valve (without actuator)

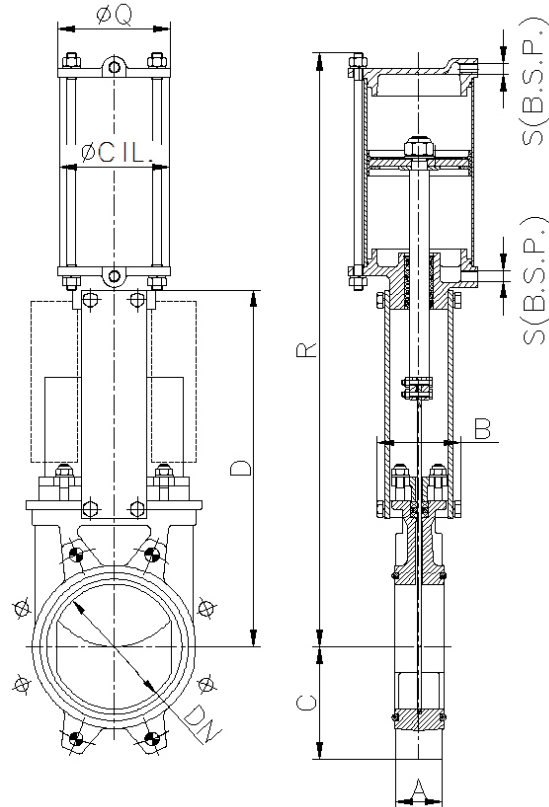

Fig. 18

ND	ΔP (bar)	A	B	C	D	R	Ø CIL.	Ø VAST	ØQ	S (B.S.P.)	Weight (Kg)
50	10	40	91	61	241	400	80	20	90	1/4"	7
65	10	40	91	68	268	442	80	20	90	1/4"	8
80	10	50	91	91	294	483	80	20	110	1/4"	9
100	10	50	91	104	334	546	100	20	135	1/4"	12
125	10	50	101	118	367	630	125	25	170	1/4"	18
150	10	60	101	130	419	692	125	25	170	1/4"	22
200	8	60	118	159	525	869	160	30	215	1/4"	37
250	6	70	118	196	626	1032	200	30	270	3/8"	58
300	6	70	118	230	726	1182	200	30	270	3/8"	72
350	5	96	290	254	797	1379	250	40	382	3/8"	130
400	5	100	290	287	903	1535	250	40	382	3/8"	148
450	3	106	290	304	989	1677	300	45	382	1/2"	235
500	3	110	290	340	1101	1839	300	45	444	1/2"	260
600	3	110	290	398	1307	2145	300	45	508	1/2"	334

Table. 8

SINGLE-ACTING PNEUMATIC CYLINDER

CMO Valves single-acting pneumatic actuators are designed to work at a pressure between 6 and 10 kg/cm².

10 bar is the maximum admissible air pressure. For air pressures below 6 bar please consult manufacturer.

Available (spring closes or spring opens).

The jacket is made of aluminium, the covers of nodular cast iron or carbon steel, the rod of AISI304, the piston of rubber-coated steel and the O-ring seals of nitrile.

The actuator design is spring activated for valves with diameters up to ND200. For larger diameters the actuator contains a double-acting cylinder and an air tank which stores the volume of air necessary to perform the last movement in the event of a fault.

Note: Please see the “**CMO Valves** Pneumatic Actuators” catalogue if you require further information.

B = Max. width of the valve (without actuator)

D = Max. height of the valve (without actuator)

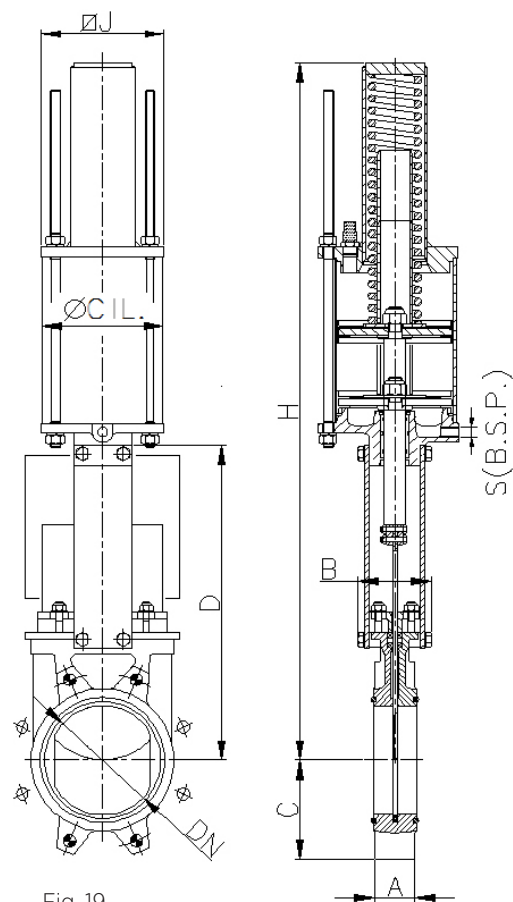

Fig. 19

ND	ΔP (bar)	A	B	C	D	H	ØJ	Ø CIL.	Ø VAST	S (B.S.P.)	Weigth (Kg)
50	10	40	91	61	241	781	135	125	25	1/4"	19
65	10	40	91	68	268	806	135	125	25	1/4"	22
80	10	50	91	91	294	833	135	125	25	1/4"	23
100	10	50	91	104	334	873	135	125	25	1/4"	24
125	10	50	101	118	367	909	135	160	30	1/4"	35
150	10	60	101	130	419	960	135	160	30	1/4"	36
200	8	60	118	159	525	1355	170	200	30	3/8"	66

Table. 9

ACTUADOR ELÉCTRICO

This actuator is automatic and includes the following parts

- Electric motor
- Stem
- Yoke

THE ELECTRIC MOTOR INCLUDES

- Emergency manual handwheel
- Limit switches
- Torque switches

OPTIONS

- Different types and brands
- Non-rising stem.

FLANGES

- ISO 5210 / DIN 3338.

AVAILABLE

- ND 50 to ND 600.
- From ND600 (inclusive) the actuator has a gearbox
- Other pressures on request.

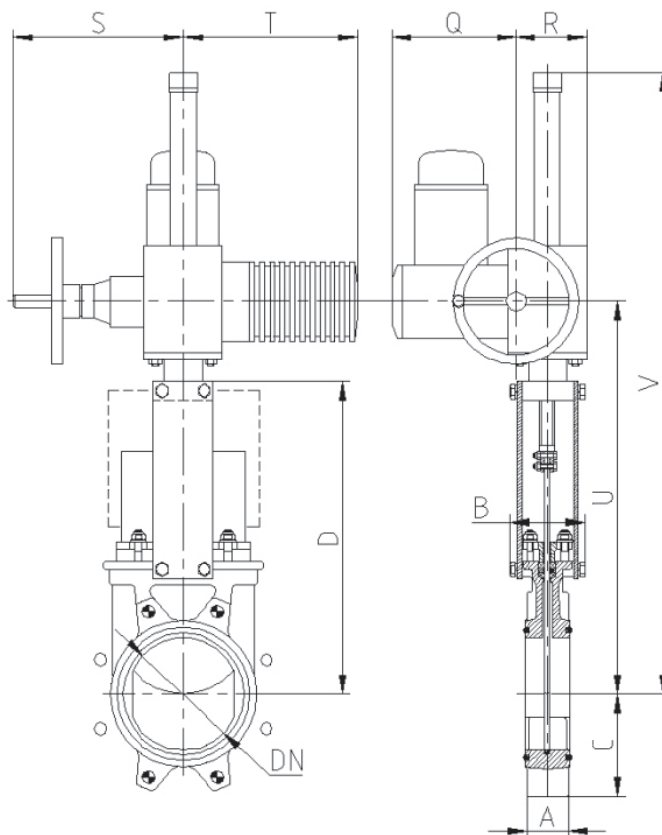

Fig. 20

* Others ND on request.

ND	ΔP (bar)	A	B	C	D	Q	R	S	T	U	V	Weigth (Kg)
50	10	40	91	61	241	197	102	234	265	347	587	24
65	10	40	91	68	268	197	102	234	265	374	614	25
80	10	50	91	91	294	197	102	234	265	400	640	26
100	10	50	91	104	334	197	102	234	265	440	680	27
125	10	50	101	118	367	197	102	234	265	473	713	30
150	10	60	101	130	419	197	102	234	265	525	765	32
200	8	60	118	159	525	197	102	234	265	640	880	42
250	6	70	118	196	626	197	102	234	265	741	981	55
300	6	70	118	230	726	197	102	234	265	841	1141	72
350	5	96	290	254	797	197	115	256	282	944	1347	99
400	5	100	290	287	903	197	115	256	282	1050	1550	136
450	3	106	290	304	989	222	153	325	385	1147	1847	166
500	3	110	290	340	1101	222	153	325	385	1259	1959	245
600	3	110	290	398	1307	222	153	325	385	1465	2165	362

Table. 10

HYDRAULIC ACTUATOR (Oil pressure: 135 bar)

B = Max. width of the valve (without actuator)

D = Max. height of the valve (without actuator)

THE HYDRAULIC ACTUATOR INCLUDES

- Hydraulic cylinder
- Yoke

AVAILABLE

- DN50 a DN600

Different types and brands available according to customer's requirements.

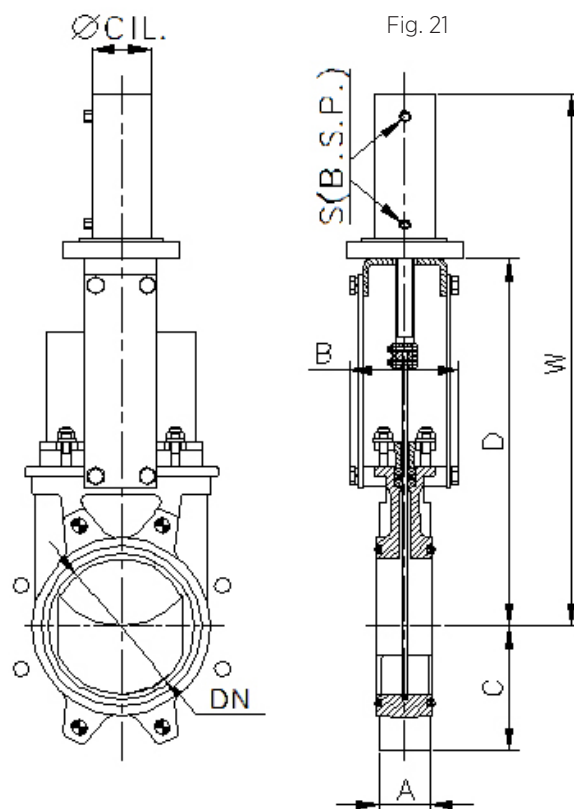

ND	ΔP (bar)	A	B	C	D	W	ø CIL	ø VAST	S (B.S.P.)	CAP. ACEITE (dm ³)	Weigth (Kg)
50	10	40	91	61	241	457	25	18	3/8"	0.03	7
65	10	40	91	68	268	500	25	18	3/8"	0.04	8
80	10	50	91	91	294	560	32	22	3/8"	0.08	9
100	10	50	91	104	334	620	32	22	3/8"	0.09	12
125	10	50	101	118	367	683	40	28	3/8"	0.18	15
150	10	60	101	130	419	755	50	28	3/8"	0.32	20
200	8	60	118	159	525	926	50	28	3/8"	0.42	31
250	6	70	118	196	626	1077	50	28	3/8"	0.52	44
300	6	70	118	230	726	1246	63	36	3/8"	0.98	62
350	5	96	290	254	797	1376	63	36	3/8"	1.14	100
400	5	100	290	287	903	1532	80	45	3/8"	2.11	138
450	3	106	290	304	989	1707	80	45	3/8"	2.36	161
500	3	110	290	340	1101	1869	80	45	3/8"	2.61	223
600	3	110	290	398	1307	2176	100	56	1/2"	4.87	325

Table. 11

INFORMATION ABOUT FLANGE DIMENSIONS

EN 1092-2 PN10

ND	ΔP (bar)	•	o	MÉTRIC	PROF.	$\varnothing K$
50	10	4	-	M 16	8	125
65	10	4	-	M 16	8	145
80	10	4	4	M 16	9	160
100	10	4	4	M 16	9	180
125	10	4	4	M 16	9	210
150	10	4	4	M 20	10	240
200	8	4	4	M 20	10	295
250	6	6	6	M 20	12	350
300	6	6	6	M 20	12	400
350	5	12	4	M 20	21	460
400	5	12	4	M 24	21	515
450	3	16	4	M 24	22	565
500	3	16	4	M 24	22	620
600	3	16	4	M 27	22	725

Table. 12

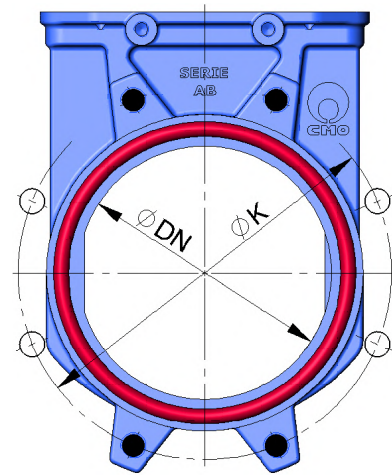

Fig. 22

- BLIND TAPED HOLES
- o THROUGH HOLE

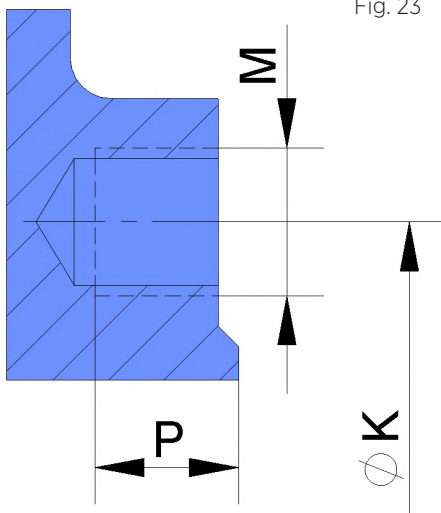

Fig. 23

ANSI B16, Clase 150

ND	ΔP (bar)	•	o	R UNC	PROF.	$\varnothing K$
2"	10	4	-	5/8"	8	120,6
2 1/2"	10	4	-	5/8"	8	139,7
3"	10	4	-	5/8"	9	152,4
4"	10	4	4	5/8"	9	190,5
5"	10	4	4	3/4"	9	215,9
6"	10	4	4	3/4"	10	241,3
8"	8	4	4	3/4"	10	298,4
10"	6	6	6	7/8"	12	361,9
12"	6	6	6	7/8"	12	431,8
14"	5	8	4	1"	21	476,2
16"	5	12	4	1"	21	539,7
18"	3	12	4	1 1/8"	22	577,8
20"	3	16	4	1 1/8"	22	635
24"	3	16	4	1 1/4"	22	749,3

Table. 13