

GA



## BIDIRECTIONAL KNIFE GATE VALVE

### DESCRIPTION

- Bidirectional knife gate valve.
- Valve suitable for use as end-of-line.
- Monobloc cast iron body.
- Stainless steel through-conduit gate.
- Two rubber sleeves.
- Provides high flow rates with low pressure drops.
- Various seat materials available.
- Face-to-face distance in accordance with **CMO Valves**.

### GENERAL APPLICATIONS

This knife gate valve is suitable for working in the mining industry, in loaded fluid transport lines such as water with stones, sludge, etc, and, in general, for abrasive fluids in the chemical industry and waste water.

Designed for the following applications

- Mining services
- Sewage treatment
- Electrical power stations
- Chemical plants
- Energy sector
- Thermal power stations

### SIZES

ND50 a ND1500 (larger sizes to order).

### WORKING PRESSURE ( $\Delta P$ )

ND 50-600 = 10 bar  
 ND 700-900 = 4 bar  
 ND 1000-1500 = 2 bar

The pressures indicated in the table can be used in either of the valve's two directions..

### FLANGE BOREHOLE

ND PN10 & ANSI B16.5 (150 LB)

### OTHERS COMMONLY USED

ND PN 6 ND PN 16 ND PN 25 JIS standard , Australian standard, British standard.

### SERIE - GA

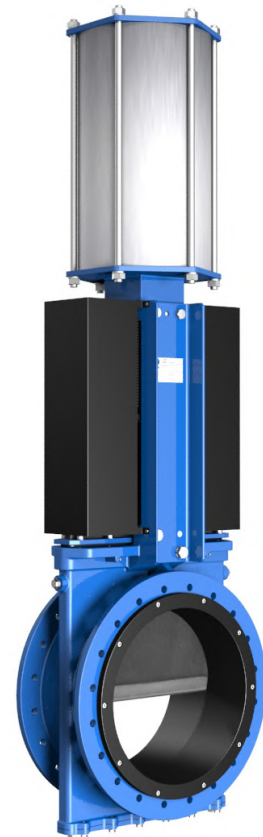

### DIRECTIVAS

- Pressure Equipment Directive:  
**(PED) ART 4.3 /CAT.1.**
- Potential Explosive Atmospheres Directive:  
**(ATEX)CAT.3 ZONA 2 y 22 GD**

\* For further information on categories and zones please contact the *Technical-Commercial Dept. CMO VALVES*.



### QUALITY DOSSIER

- All valves are tested hydrostatically at **CMO Valves**, and material and test certificates can be provided.
- Body test = working pressure x 1.5.
- Seal test = working pressure x 1.1.

## Advantages

The main characteristic of this knife-gate valve is that it provides a full continuous flow. This means that in open position it produces no cavities and there is no turbulence in the fluid. Valve suitable for use as end-of-line. The GA valve body is a single monobloc piece.

The stem protection hood is independent from the handwheel securing nut, this means the hood can be disassembled without the need to release the handwheel. This advantage allows regular maintenance operations to be carried out, such as lubricating the stem, etc. The **CMO Valves** stem is made from stainless steel 18/8. This is another additional benefit, since some manufacturers supply it with 13% chrome, which quickly rusts.

The operating wheel is manufactured in nodular cast GJS-500. Some manufacturers supply it in common cast-iron, which can lead to breakage in the event of very high operation torque or a bang.

The yoke has a compact design with the bronze actuator nut protected in a sealed and lubricated box. This makes it possible to move the valve with a key, even without the handwheel (in other manufacturers' products this is not possible).

The pneumatic actuator's upper and lower covers are made of GJS-500 nodular cast iron, making them highly shock resistant. This characteristic is essential in pneumatic actuators.

The pneumatic cylinder sealing joints are commercial products and can be purchased worldwide. This means it is not necessary to contact **CMO Valves** every time a sealing joint is required

### STANDARD COMPONENTS LIST

COMPONENT	CAST IRON	STAINLESS STEEL
1 Body	GJS-500	CF8M
2 Gate	AISI304	AISI316
3 Packing gland	STEEL	AISI316
4 Packing seal	NATURAL RUBBER	
5 Gasket	LUBRICATED GASKET	
6 Bottom cover	STEEL	AISI316
7 Sleeve	NATURAL RUBBER	
8 Retainer sleeve	NATURAL RUBBER	ACERO
9 Stem	AISI303	AISI303
10 Yoke	GJS-500	GJS-500
11 Stem nut	BRONZE	BRONZE
12 Handwheel	GJS-500	GJS-500
13 Stopper nut	STEEL	STEEL
14 Hood nut	5.6 ZINC	5.6 ZINC
15 Hood	STEEL	STEEL
16 Protection cap	PLASTIC	PLASTIC

(Table 1)

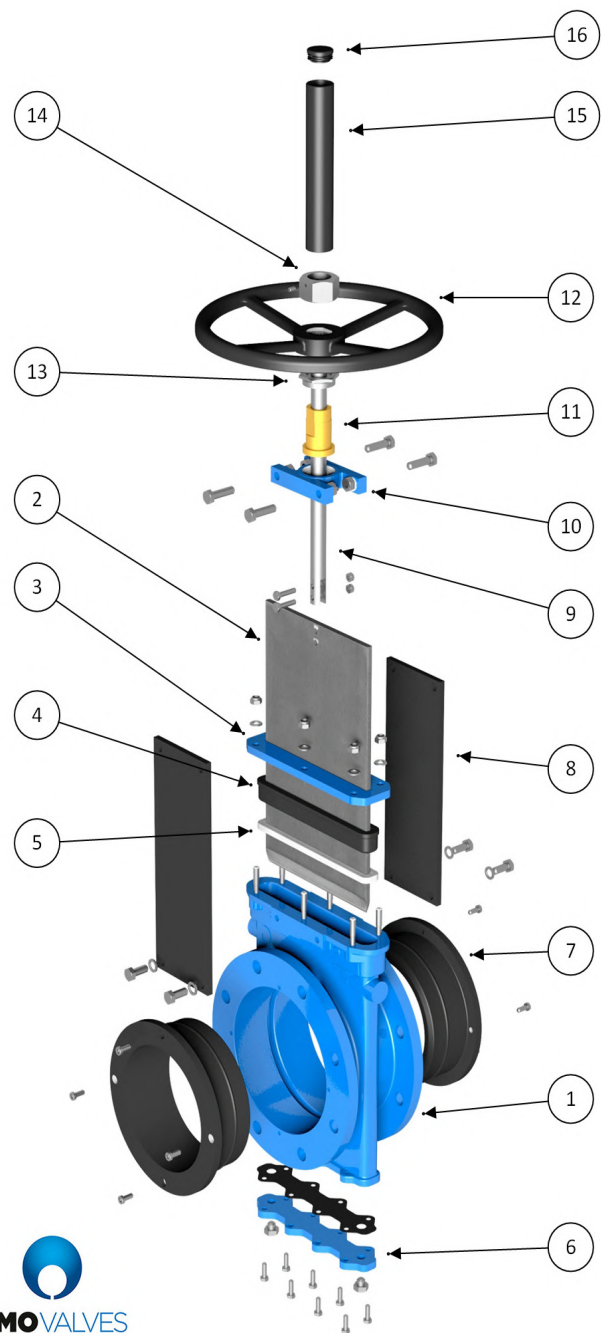

(Fig. 2).



**Note:** The numbers of the images refer to the list of components in the table.

## DESIGN CHARACTERISTICS

### 1. BODY

Reinforced monobloc cast iron body. The body provides a full continuous flow. This means that in open position it produces no cavities and, therefore, there is no turbulence in the fluid and the load loss is minimal. For diameters greater than DN600 the body is machine-welded with the necessary reinforcements to withstand the maximum working pressure. Designed with full passage to provide large flows with small losses of load. The body's internal design prevents any build-up of solids in the seal area. The standard manufacturing materials are GJS-500 and CF8M stainless steel. Other materials such as A216WCB carbon steel and stainless steel alloys (AISI316Ti, Duplex, 254SMO, Uranus B6, Ni-Resist, Ductile Ni-Resist, etc.) are available to order. As standard, iron or carbon steel valves are painted with an anti-corrosive protection of 150 microns of EPOXY (colour RAL 5015). Other types of anti-corrosive protections are available to order.

### 2. THROUGH-CONDUIT GATE

The standard manufacturing materials are AISI304 stainless steel in valves with GJS-500 body, and AISI316 stainless steel in valves with CF8M body. Other materials or combinations can be supplied to order. The through-conduit gate is polished on both sides to provide a smooth contact surface with the resilient seal. At the same time, the sharp edges on the gate are rounded to prevent the seal being cut. There are different degrees of polishing, anti-abrasion treatments and various options to adapt the valves to the customer's requirements.

### 3. SEAT (sealtight)

The GA valve seat comprises two rubber sleeves located symmetrically on each side of the body, both secured with sleeve retainers.

Both the sleeve retainers and the sleeves are made of natural rubber with a metal core which helps to keep their shape and also prevent deformations. Whilst the valve is in open position, the sleeves' elasticity ensures they are joined together permanently, preventing the accumulation of solids between the two parts of the body.

The GA valve is designed for abrasive fluids, and, therefore, the sleeves protect the entire surface of the body which would be exposed to the abrasive flow. For easier maintenance, the sleeves can be replaced from outside the valve. It is a symmetrical two-piece seat; see the drawing of a seat.

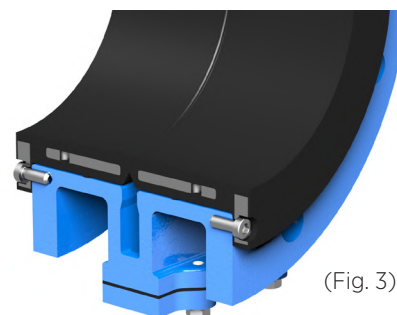

(Fig. 3).

### Sealtight materials

#### NATURAL RUBBER

This is the standard hermetic seal fitted in CMO Valves GA model valves. It can be used in multiple applications at temperatures below 90°C with abrasive products, and it provides the valve with 100% sealtight integrity. Application: fluids in general.

#### POLYURETHANE

It can be used in multiple applications at temperatures not exceeding 90 ° C, with abrasive products. It provides the valve with 100% tightness. Application: fluids in general.

(Table 2)

#### EPDM

Recommended for temperatures below 90°C\*. Provides the valve with 100% sealtight integrity. Application: water and acids.

#### NITRILE

Used in fluids containing fats or oils at temperatures no higher than 90°C\*. Provides the valve with 100% sealtight integrity

SEAT/SEALS		
MATERIAL	Tª MÁX (°C)	APLICACIONES
Natural Rubber	90°	General
Polyurethane	90°	General
EPDM (E)	90° *	Non-mineral oils, water and acids.
Nitrile (N)	90° *	Hydrocarbons, oils and greases
Vitón (V)	200°	Hydrocarbons and solvents

**NOTE:** More details and other materials available to order.

\* ⇔ **EPDM y Nitrile:** possible up to max temp 120°C on request

#### VITON

Suitable for corrosive applications and high temperatures of up to 190°C and peaks of 210°C. Provides the valve with 100% sealtight integrity.

## 4. GASKET

standard gasket is composed of a specially designed EPDM O-ring which provides sealtight integrity between the body and the gate, preventing any type of leakage to the atmosphere. It also has a lubricated gasket strip to help the valve's operation during the opening and closing functions. It is located in an easily accessible place and can be replaced without dismantling the valve from the pipeline.

## 5. STEM

The valve stem is made from stainless steel 18/8. This characteristic makes it highly resistant and provides excellent properties against corrosion. The valve design can be rising stem or non-rising stem. When a rising stem is required for the valve, a stem hood is supplied to protect the stem from contact with dust and dirt, besides keeping it lubricated.

## 6. PACKING GLAND

The packing gland allows uniform force and pressure to be applied to the gasket to ensure sealtight integrity. As standard, valves with steel body include steel packing glands, whilst valves with stainless steel body have stainless steel packing glands.

## 7. ACTUATORS

It is possible to supply all types of actuators, with the advantage that the **CMO Valves** design is completely interchangeable. This design means customers can change the actuator themselves without any additional assembly accessories. A design characteristic of **CMO Valves** valves is that all actuators are interchangeable.

### Manual Actuators

- Handwheel with rising stem / Non-rising stem
- Chainwheel / Lever
- Gearbox / Others (square stem, etc)

### Wide range of accessories available

- Mechanical stoppers
- Locking devices
- Emergency manual actuators
- Electrovalves
- Positioners
- Limit switches
- Proximity detectors
- Straight floor stand (fig. 5)
- Leaning floor stand (fig. 6)

### Automatic Actuators

- Electric actuator
- Pneumatic cylinder
- Hydraulic cylinder

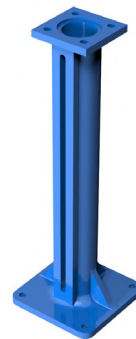

(Fig.5)



(Fig.6)

Stem extensions have also been developed, allowing the actuator to be located far away from the valve, to suit all needs. Please check with our technicians beforehand.

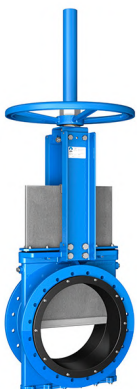

Handwheel with rising stem



Pneumatic actuator



Electric-motor actuator



Hydraulic actuator



Handwheel with gearbox



## ACCESSORIES AND OPTIONS

Different accessories are available to adapt the valve to specific working conditions such as:

### MIRROR POLISHED THROUGH-CONDUIT GATE

The mirror polished through-conduit gate is especially recommended in the food industry and, as standard, in applications in which solids can stick to the gate. It is an alternative to ensure the solids slide off and do not stick to the gate.

### PTFE COATED THROUGH-CONDUIT GATE

As with the mirror polished through-conduit gate, this improves the valve's resistance to products which can stick to the gate.

### STELLITED THROUGH-CONDUIT GATE

Stellite is added to the inner circle of the through-conduit gate to protect it from abrasion.

### SCRAPER IN THE GASKET

Its function is to clean the gate during the opening movement and prevent possible damage to the gasket.

### FLUSHING HOLES IN THE BODY

Several holes are drilled in the body to flush air, steam or other fluids out with the aim of cleaning the valve seat before sealing.

### CASED BODY

Recommended in applications in which the fluid can harden and solidify inside the valve body. An external casing keeps the body temperature constant, preventing the fluid from solidifying.

### ELECTROVALVES

For air distribution to pneumatic actuators.

### JUNCTION BOXES, WIRING AND PNEUMATIC PIPING

Units supplied fully assembled with all the necessary accessories

### MECHANICAL LIMIT SWITCHES, INDUCTIVE SENSORS AND POSITIONERS

Limit switches or sensors are installed to indicate precise valve position, as well as positioners to indicate continuous position (fig. 7).

### MECHANICAL LOCKING DEVICE

Allows the valve to be mechanically locked in a set position for long periods.

### STROKE LIMITING MECHANICAL STOPS

Allow the stroke to be mechanically adjusted, limiting the valve run.

### EMERGENCY MANUAL ACTUATOR (HAND WHEEL/GEARBOX)

Allows manual operation of the valve in the event of power or air failure.

### INTERCHANGEABLE ACTUATORS

All actuators are easily interchangeable

### ACTUATOR OR YOKE SUPPORT

Made of EPOXY-coated steel (or stainless steel to order), its robust design gives it great rigidity in order to withstand the most adverse operation conditions.

### EPOXY COATING

All cast iron and carbon steel bodies and components in C.M.O. valves are EPOXY coated, giving the valves great resistance to corrosion and an excellent finish. C.M.O.'s standard colour is blue, RAL-5015.

### THROUGH-CONDUIT GATE SAFETY GUARD

In accordance with European Safety Standards ("EC" marking), **CMO Valves** automatic valves are fitted with metal guards in the gate run in order to prevent objects from being accidentally caught or dragged along.



(Fig. 7).

## TYPES OF EXTENSION

When the valve needs to be operated from a distance, the following different types of actuators can be fitted:

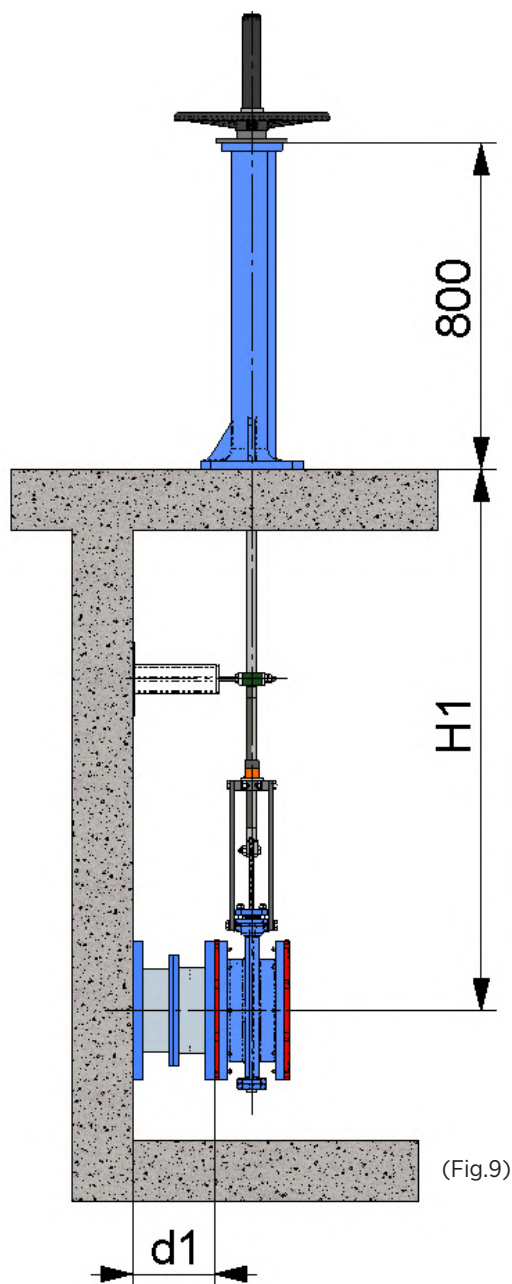

**1.- EXTENSION: FLOOR STAND** This extension is done by coupling a rod to the stem. The desired extension is achieved by defining the length of the rod. A floor stand is normally installed to support the actuator.

The definition variables are as follows:

Las variables de definición son:

**H1:** Distance from the valve shaft to the base of the stand.

**d1:** Separation from the wall to the end of the connecting flange.

### CHARACTERISTICS:

Can be coupled to any type of actuator.

A stem support-guide is recommended (fig. 8) every 1.5 m.

The standard floor stand is 800 mm high (fig. 9). Other floor stand measurements available to order.

Option of fitting an indicator rule in order to determine the degree of opening of the valve.

Option of leaning floor stand (fig. 10).

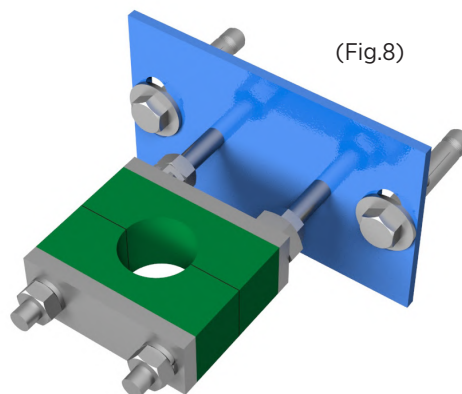

(Fig.8)



(Fig.10)

### COMPONENTS LIST

COMPONENT	STANDARD VERSION
Stem	AISI 303
Rod	AISI 304
Guide-support	Carbon steel with EPOXI coating
Slide	Nylon
Floor Stand	GJS-500 with EPOXY coating

(Table 3)

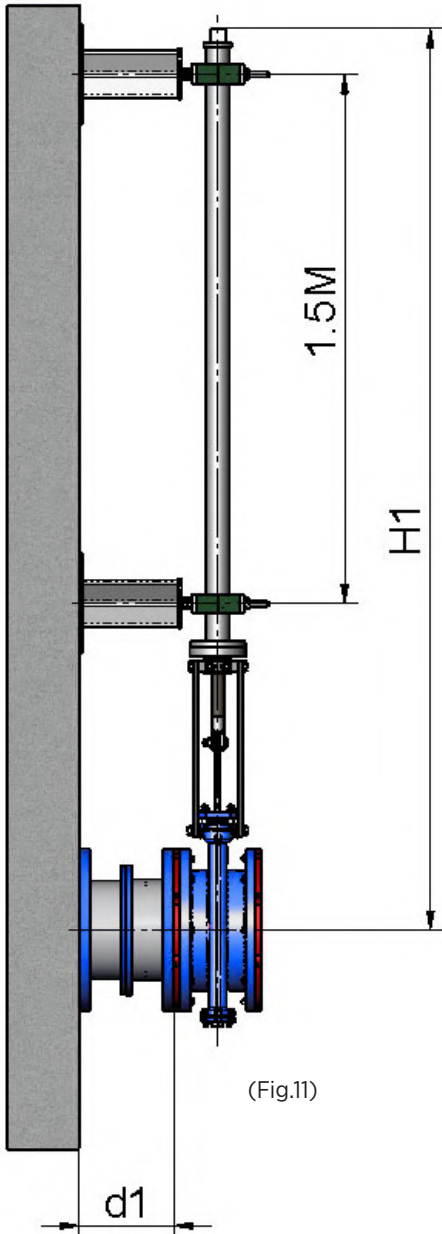

(Fig.11)

## 2.- EXTENSION: PIPE (Fig 11)

This consists of raising the actuator. The pipe will rotate with the wheel or key when the valve is operated, although this will always remain at the same height.

The definition variables are as follows:

**H1:** Distance from the valve shaft to the required height of the actuator.

**d1:** Separation from the wall to the end of the connecting flange.

## CHARACTERISTICS

- Standard actuators: handwheel and square stem.
- A pipe support-guide is recommended every 1.5 m.
- The standard materials are: Stainless steel or EPOXY coated carbon steel.

## 3.-EXTENDED SUPPORT PLATES (Fig 11)

When a large extension is required, it can be achieved by extending the support plates. An intermediate yoke can be fitted to reinforce the support plates structure..

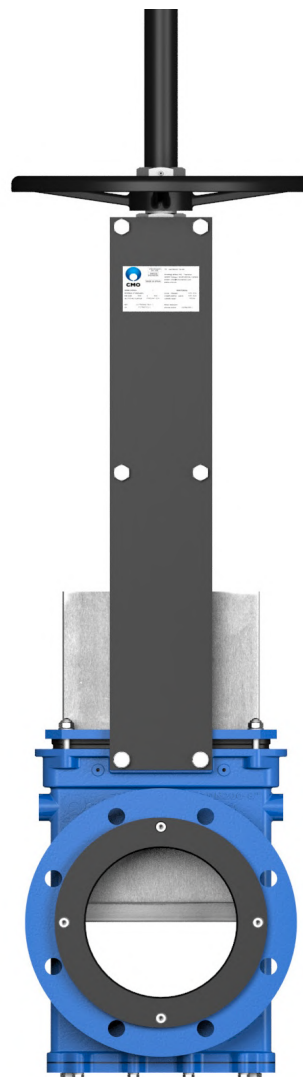

(Fig.12)

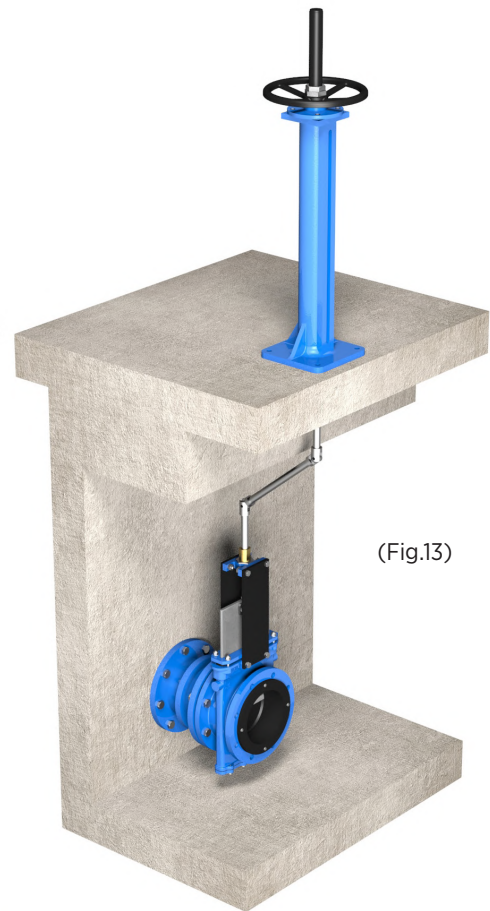

(Fig.13)

## 4.-UNIVERSAL JOINT (Fig 13)

If the valve and the actuator are not in correct alignment, the problem can be resolved by fitting a universal joint.



## HANDWHEEL WITH RISING STEM

The definition variables are as follows:

**H1:** Distance from the valve shaft to the required height of the actuator.

**d1:** Separation from the wall to the end of the connecting flange.

### OPTIONS:

- Locking devices.
- Extensions: stand, pipe, plates, etc.
- DN higher than those shown in the table.

### ACTUATOR COMPRISING:

- Handwheel.
- Stem.
- Nut.
- Stem protection hood.

### AVAILABLE:

- Standard ND50 a ND1000.
- Other ND to order.

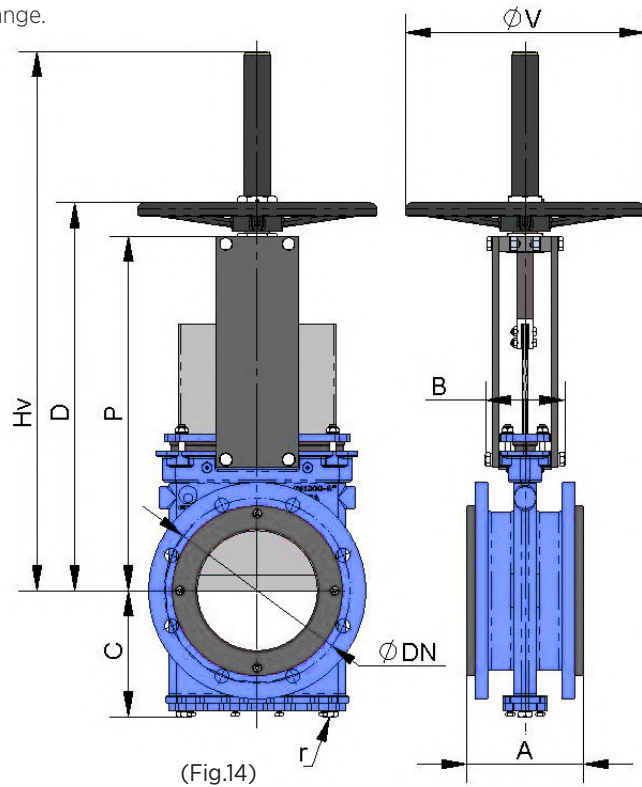

ND	ΔP (bar)	A	B	C	P	D	Hv	r (B.S.P.)
50	10	175	109	106	280	319	225	1/4"
65	10	175	109	113	306	345	225	1/4"
80	10	175	109	122	332	372	225	1/4"
100	10	175	109	136	368	407	225	1/4"
125	10	178	126	153	421	474	325	1/4"
150	10	178	126	168	466	519	325	1/4"
200	10	185	126	199	565	618	325	3/8"
250	10	226	197	234	626	749	450	1/2"
300	10	258	197	272	739	837	450	1/2"
350	10	258	350	297	842	942	--	1/2"
400	10	279	350	330	933	1033	--	3/4"
450	10	321	350	355	1019	1119	--	3/4"
500	10	367	380	391	1156	1256	--	3/4"
600	10	371	400	461	1338	1438	--	1"
700	6	378	400	534	1425	1525	--	1"
750	6	395	400	559	1520	1620	--	1"
800	6	411	400	584	1615	1715	--	1"
900	6	470	400	649	1823	1923	--	1"
1000	4	534	440	699	1992	2092	--	1"

(Table 4)



## HANDWHEEL WITH NON-RISING STEM

Suitable when no size limitations exist.

The definition variables are as follows:

**B = max. width** of the valve (no actuator).

**P = max. height** of the valve (no actuator).

**OPTIONS:**

- Square stem.
- Locking devices.
- Extensions: stand, pipe, plates, etc.
- DN higher than those shown in the table.

**ACTUATOR COMPRISING:**

- Handwheel.
- Stem.
- Guide bushing in the yoke.
- Nut.

**AVAILABLE:**

- ND50 to ND1000, other ND to order.
- From ND350 (inclusive) the actuator has a gearbox.
- Other pressures on request.

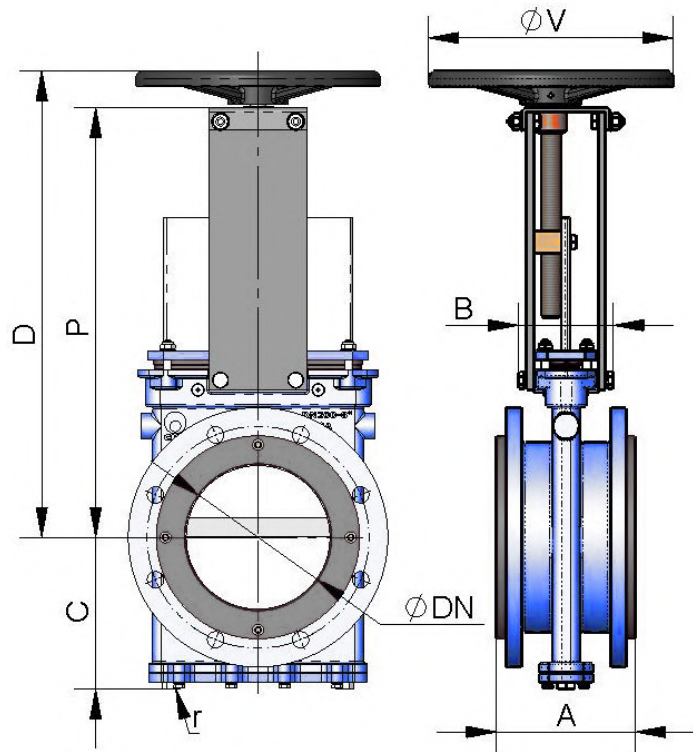

(Fig.15)

ND	ΔP (bar)	A	B	C	P	D	øV	r (B.S.P.)
50	10	175	109	106	280	319	225	1/4"
65	10	175	109	113	306	345	225	1/4"
80	10	175	109	122	332	372	225	1/4"
100	10	175	109	136	368	407	225	1/4"
125	10	178	126	153	421	474	325	1/4"
150	10	178	126	168	466	519	325	1/4"
200	10	185	126	199	565	618	325	3/8"
250	10	226	197	234	626	749	450	1/2"
300	10	258	197	272	739	837	450	1/2"
350	10	258	350	297	842	942	--	1/2"
400	10	279	350	330	933	1033	--	3/4"
450	10	321	350	355	1019	1119	--	3/4"
500	10	367	380	391	1156	1256	--	3/4"
600	10	371	400	461	1338	1438	--	1"
700	6	378	400	534	1425	1525	--	1"
750	6	395	400	559	1520	1620	--	1"
800	6	411	400	584	1615	1715	--	1"
900	6	470	400	649	1823	1923	--	1"
1000	4	534	440	699	1992	2092	--	1"

(Table 5)

## HANDWHEEL - CHAIN

Widely used in raised installations with difficult access, the handwheel is fitted in vertical position.

The definition variables are as follows:

**B = max. width** of the valve (no actuator).

**P = max. height** of the valve (no actuator).

### OPTIONS:

- Locking devices.
- Extensions: stand, pipe, plates, etc.
- Non-rising stem.
- ND higher than those shown in the table.

### ACTUATOR COMPRISING:

- Handwheel.
- Stem.
- Nut.
- Hood.

### AVAILABLE:

- ND50 to ND1000, other ND to order.
- From ND350 (inclusive) the actuator has a gearbox.
- Other pressures on request.

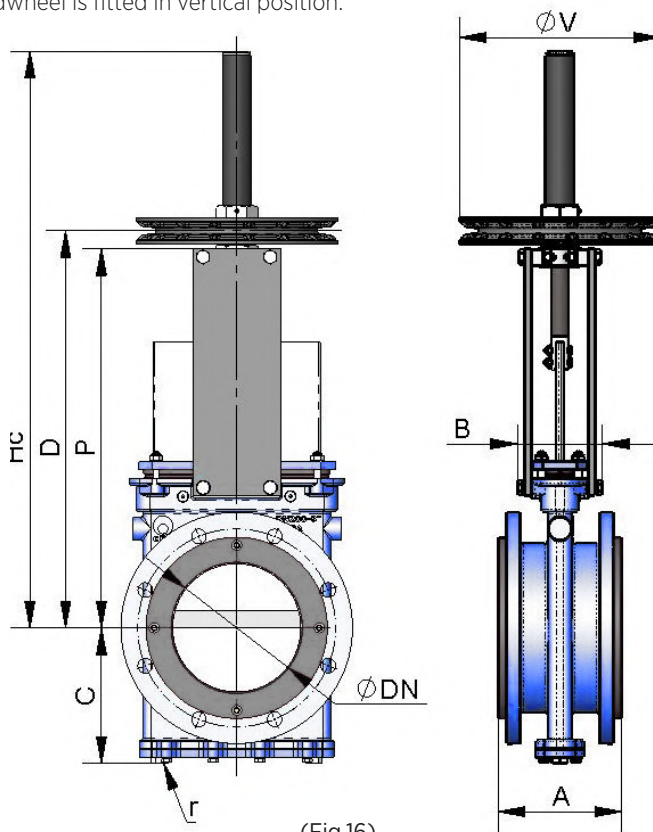

(Fig.16)

ND	ΔP (bar)	A	B	C	P	D	ØV	r (B.S.P.)
50	10	175	109	106	280	319	225	1/4"
65	10	175	109	113	306	345	225	1/4"
80	10	175	109	122	332	372	225	1/4"
100	10	175	109	136	368	407	225	1/4"
125	10	178	126	153	421	474	325	1/4"
150	10	178	126	168	466	519	325	1/4"
200	10	185	126	199	565	618	325	3/8"
250	10	226	197	234	626	749	450	1/2"
300	10	258	197	272	739	837	450	1/2"
350	10	258	350	297	842	942	--	1/2"
400	10	279	350	330	933	1033	--	3/4"
450	10	321	350	355	1019	1119	--	3/4"
500	10	367	380	391	1156	1256	--	3/4"
600	10	371	400	461	1338	1438	--	1"
700	6	378	400	534	1425	1525	--	1"
750	6	395	400	559	1520	1620	--	1"
800	6	411	400	584	1615	1715	--	1"
900	6	470	400	649	1823	1923	--	1"
1000	4	534	440	699	1992	2092	--	1"

(Table 6)

## LEVER

This is a fast operation actuator.

The definition variables are as follows:

**B = max. width** of the valve (no actuator).

**P = max. height** of the valve (no actuator).

### THE ACTUATOR INCLUDES:

- Lever.
- Rod.
- Guide bushing.
- External locking devices to hold the position.

### AVAILABLE:

- ISO 5210 / DIN 3338 Flanges.
- Other ND to order.
- Other pressures on request

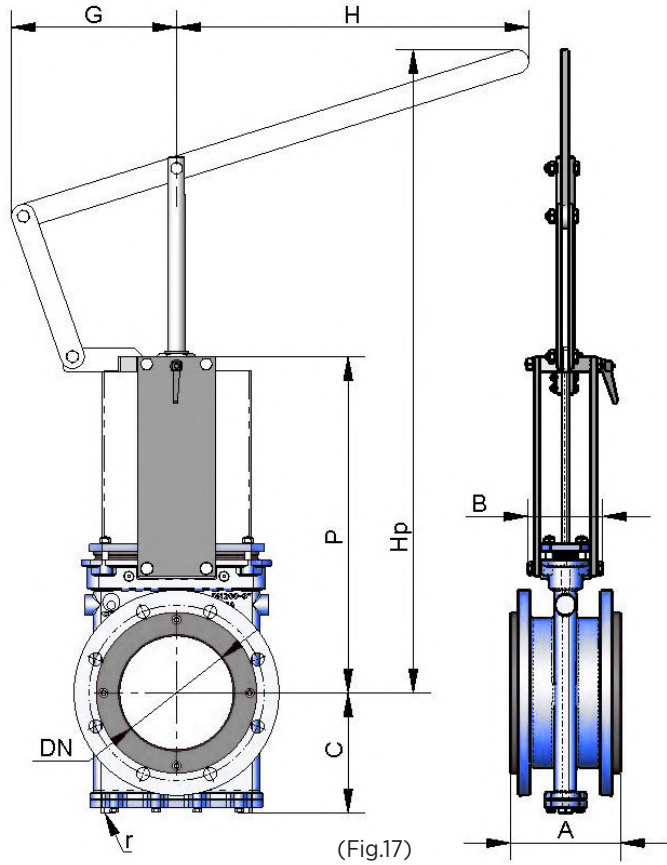

ND	$\Delta P$ (bar)	A	B	C	P	G	Hp	H	r (B.S.P.)
50	10*	175	109	106	280	155	543	325	1/4"
65	10*	175	109	113	306	155	564	325	1/4"
80	10*	175	109	122	332	155	587	325	1/4"
100	10*	175	109	136	368	155	639	325	1/4"
125	10*	178	126	153	421	155	942	425	1/4"
150	10*	178	126	168	466	155	1002	425	1/4"
200	10*	185	126	199	565	290	1068	620	3/8"

(Table 7)



## GEARBOX

It is recommendable for ND greater than 350

The definition variables are as follows:

**B = max. width** of the valve (no actuator).

**P = max. height** of the valve (no actuator).

### OPTIONS:

- Chainwheel.
- Locking devices.
- Extensions: stand, pipe, plates, etc.
- Non-rising stem.

### ACTUATOR COMPRISING:

- Stem.
- Yoke.
- Bevel gearbox
- Handwheel.

Standard reduction ratio = 4 to 1

### AVAILABLE:

- DN50 to DN1500, other DN to order.
- Other pressures on request.

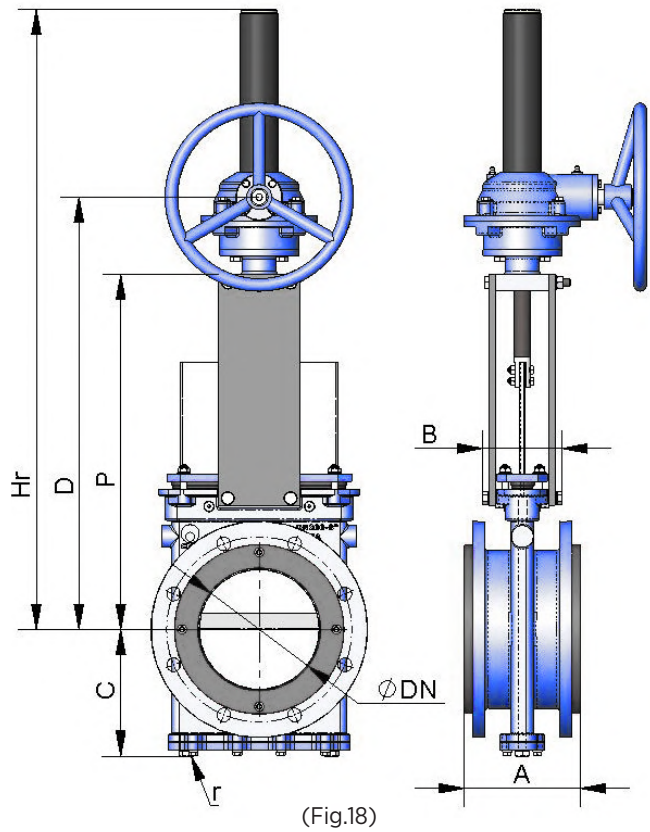

ND	$\Delta P$ (bar)	A	B	C	P	D	Hr	r (B.S.P.)
50	10	175	109	106	280	402	581	1/4"
65	10	175	109	113	306	446	621	1/4"
80	10	175	109	122	332	454	633	1/4"
100	10	175	109	136	368	490	669	1/4"
125	10	178	126	153	421	565	800	1/4"
150	10	178	126	168	466	589	848	1/4"
200	10	185	126	199	565	689	948	3/8"
250	10	226	197	234	626	735	1119	1/2"
300	10	258	197	272	739	833	1217	1/2"
350	10	258	350	297	842	935	1384	1/2"
400	10	279	350	330	933	1028	1627	3/4"
450	10	321	350	355	1019	1120	1719	3/4"
500	10	367	380	391	1156	1275	1889	3/4"
600	10	371	400	461	1338	1457	2171	1"
700	6	378	400	534	1530	1764	2440	1"
750	6	395	400	559	1637	1860	2555	1"
800	6	411	400	584	1733	1950	2807	1"
900	6	470	400	649	1954	2090	3148	1"
1000	4	534	440	699	2160	2233	3579	1"
1100	4	534	440	730	2310	2446	3779	1 1/2"
1200	4	537	480	775	2551	2522	3807	1 1/2"
1300	4	537	480	805	2882	3053	4482	1 1/2"
1400	4	533	520	875	3250	3458	4952	1 1/2"
1500	4	533	520	925	3695	3910	5475	1 1/2"

(Table 8)

## DOUBLE-ACTING PNEUMATIC CYLINDER

The definition variables are as follows:

**B = max. width** of the valve (no actuator).  
**P = max. height** of the valve (no actuator).

The air supply pressure to the cylinder is a minimum of 6 bar and a maximum of 10 bar, the air must be dry and lubricated.

If the air pressure is less than 6 bar, consult with **CMO Valves**

For DN50 to DN200 valves, the cylinder's casing and covers are made of aluminium, the rod of AISI304, the piston of rubber-coated steel and the O-ring seals are made of nitrile.

For pneumatic cylinders larger than Ø200 the covers are made of nodular cast iron or carbon steel.

To order, the actuator can also be made from stainless steel, specifically for installation in corrosive environments.

**AVAILABLE:**

- DN50 to DN700, other DN to order.
- Other pressures on request.

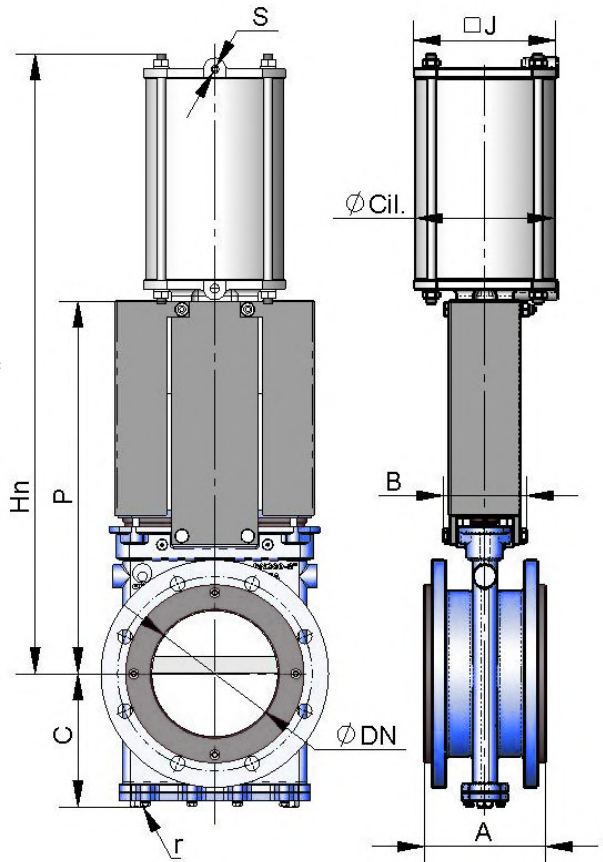

(Fig.19)

ND	ΔP (bar)	A	B	C	P	Hn	J	Ø CIL	Ø ROD	s (B.S.P.)	r (B.S.P.)
50	10	175	109	106	280	475	96	80	20	1/4"	1/4"
65	10	175	109	113	306	515	96	80	20	1/4"	1/4"
80	10	175	109	122	332	555	115	100	20	1/4"	1/4"
100	10	175	109	136	368	620	138	125	25	1/4"	1/4"
125	10	178	126	153	421	700	175	160	30	1/4"	1/4"
150	10	178	126	168	466	775	175	160	30	1/4"	1/4"
200	10	185	126	199	565	940	218	200	30	3/8"	3/8"
250	10	226	197	234	626	1140	270	250	40	3/8"	1/2"
300	10	258	197	272	739	1300	382	300	45	1/2"	1/2"
350	10	258	350	297	842	1485	444	350	45	1/2"	1/2"
400	10	279	350	330	933	1655	508	400	50	1/2"	3/4"
450	10	321	350	355	1019	1805	552	450	50	3/4"	3/4"
500	10	367	380	391	1156	2000	612	500	50	3/4"	3/4"
600	10	371	400	461	1338	2285	772	585	60	1"	1"
700	6	378	400	534	1530	2495	772	635	60	1"	1"

(Table 9)

(\*) -> Lower working pressures consult with **CMO Valves**

## SINGLE-ACTING PNEUMATIC CYLINDER

The definition variables are as follows:

**B = max. width** of the valve (no actuator).  
**P = max. height** of the valve (no actuator).

The air supply pressure to the cylinder is a minimum of 6 bar and a maximum of 10 bar; the air must be dry and lubricated.

Available for opening or closing in case of air supply failure (spring opening or closing).

The casing is made of aluminium, the covers of nodular cast iron or carbon steel, the rod of AISI304, the piston of rubber-coated steel, the O-ring seals of nitrile and the spring is made of steel

The actuator design is spring activated for valves with diameters up to DN200.

For larger diameters the actuator contains a double-acting cylinder and an air tank which stores the volume of air necessary to carry out the last movement in the event of an air supply failure.

### AVAILABLE:

- DN50 to DN200, other DN to order.
- Other pressures on request.

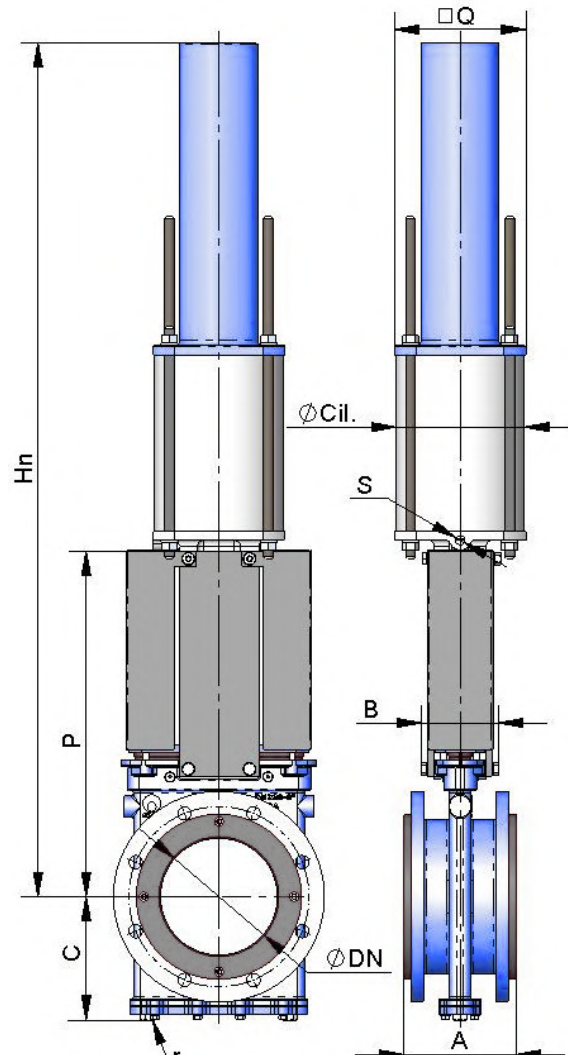

(Fig.20)

ND	ΔP (bar)	A	B	C	P	Hn	J	ø CIL	ø ROD	r (B.S.P.)
50	10	175	109	106	280	752	138	125	25	1/4"
65	10	175	109	113	306	794	138	125	25	1/4"
80	10	175	109	122	332	836	138	125	25	1/4"
100	10	175	109	136	368	906	175	160	30	1/4"
125	10	178	126	153	421	986	218	200	30	3/8"
150	10	178	126	168	466	1056	218	200	30	3/8"
200	10	185	126	199	565	1439	270	250	40	3/8"

(Table 10)



## ELECTRIC ACTUATOR

This actuator is automatic and includes the following parts:

- Electric motor.
- Stem.
- Yoke.

### OPTIONS:

- Diferentes tipos y marcas
- Husillo no ascendente.
- 
- Bridas ISO 5210 / DIN 3338
- Disponible: DN 50 a DN 1500
- Otros DN bajo consulta.
- A partir de DN350 el motor se ayuda un reductor.
- Otras presiones bajo consulta

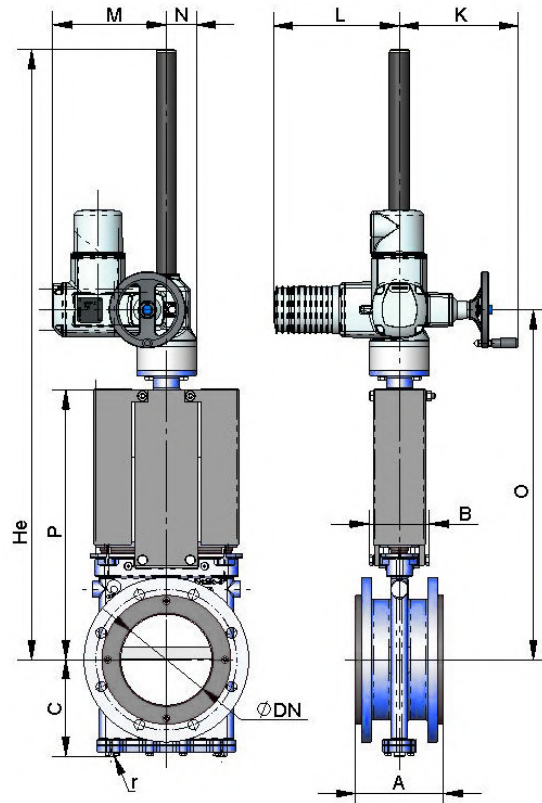

(Fig.21)

ND	ΔP (bar)	A	B	C	P	K	L	M	N	O	He	r
50	10	175	109	106	280	249	265	238	62	436	631	1/4"
65	10	175	109	113	306	249	265	238	62	462	657	1/4"
80	10	175	109	122	332	249	265	238	62	488	683	1/4"
100	10	175	109	136	368	249	265	238	62	524	719	1/4"
125	10	178	126	153	421	249	265	238	62	574	769	1/4"
150	10	178	126	168	466	249	265	238	62	624	819	1/4"
200	10	185	126	199	565	249	265	238	62	723	1033	3/8"
250	10	226	197	234	626	254	283	248	65	781	1121	1/2"
300	10	258	197	272	739	254	283	248	65	879	1219	1/2"
350	10	258	350	297	842	249	265	407	82	975	1384	1/2"
400	10	279	350	330	933	254	283	424	82	1078	1627	3/4"
450	10	321	350	355	1019	254	283	424	82	1170	1719	3/4"
500	10	367	380	391	1156	336	389	479	103	1338	1889	3/4"
600	10	371	400	461	1338	336	389	479	103	1520	2171	1"
700	6	378	400	534	1530	336	389	479	103	1831	2440	1"
750	6	395	400	559	1637	336	389	479	103	1927	2555	1"
800	6	411	400	584	1733	339	389	528	136	2017	2807	1"
900	6	470	400	649	1954	339	389	528	136	2157	3148	1"
1000	4	534	440	699	2160	339	389	528	136	2300	3579	1"
1100	4	534	440	730	2310	339	389	528	136	2513	3779	1 1/2"
1200	4	537	480	775	2551	336	389	659	170	2589	3807	1 1/2"
1300	4	537	480	805	2882	336	389	659	170	3120	4482	1 1/2"
1400	4	533	520	875	3250	336	389	659	170	3525	4952	1 1/2"
1500	4	533	520	925	3695	336	389	659	170	3975	5464	1 1/2"

(Table 11)

## HYDRAULIC ACTUATOR (Oil pressure: 135 Kg/cm<sup>2</sup>)

The definition variables are as follows:

**B = max. width** of the valve (no actuator).

**P = max. height** of the valve (no actuator).

This actuator is hidraulic and includes the following parts:

- Hydraulic cylinder.
- Yoke.

### AVAILABLE:

- ND 50 a ND 1500, otros DN bajo consulta.
- Different types and makes available according to customer's requirements.
- Other pressures on request.

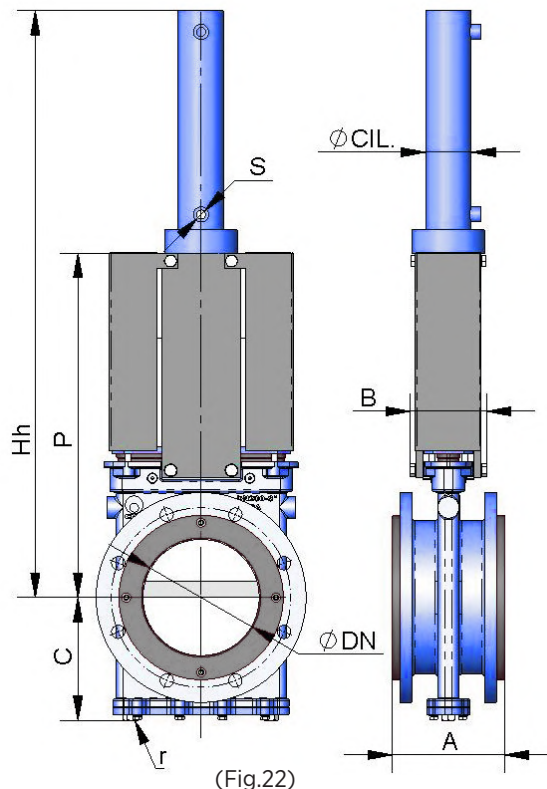

ND	ΔP (bar)	A	B	C	P	Hh	Ø CIL.	Ø ROD	S (B.S.P.)	Aceite (dm3)	r (B.S.P.)
50	10	175	109	106	280	482	25	18	3/8"	0,04	1/4"
65	10	175	109	113	306	524	25	18	3/8"	0,05	1/4"
80	10	175	109	122	332	566	25	18	3/8"	0,05	1/4"
100	10	175	109	136	368	615	32	22	3/8"	0,11	1/4"
125	10	178	126	153	421	702	40	28	3/8"	0,19	1/4"
150	10	178	126	168	466	789	50	28	3/8"	0,36	1/4"
200	10	185	126	199	565	958	50	28	3/8"	0,47	3/8"
250	10	226	197	234	626	1100	63	36	3/8"	0,91	1/2"
300	10	258	197	272	739	1272	80	36	3/8"	1,73	1/2"
350	10	258	350	297	842	1441	100	45	1/2"	3,1	1/2"
400	10	279	350	330	933	1613	125	56	1/2"	5,55	3/4"
450	10	321	350	355	1019	1766	125	56	1/2"	6,22	3/4"
500	10	367	380	391	1156	1939	125	56	1/2"	6,99	3/4"
600	10	371	400	461	1338	2273	160	70	1/2"	12,57	1"
700	6	378	400	534	1530	2410	160	70	1/2"	14,58	1"
750	6	395	400	559	1637	2576	160	70	1/2"	15,58	1"
800	6	411	400	584	1733	2742	160	70	1/2"	16,69	1"
900	6	470	400	649	1954	3053	200	90	1/2"	29,22	1"
1000	4	534	440	699	2160	3322	160	70	1/2"	20,81	1"
1100	4	534	440	730	2310	3685	200	90	1/2"	35,66	1 1/2"
1200	4	537	480	775	2551	3919	200	90	1/2"	38,96	1 1/2"
1300	4	537	480	805	2882	4565	200	90	1/2"	42,1	1 1/2"
1400	4	533	520	875	3250	5035	220	90	1/2"	55,12	1 1/2"
1500	4	533	520	925	3695	5545	220	90	1/2"	58,92	1 1/2"

(Table 12)

## INFORMATION ON FLANGE DIMENSIONS

ND	$\Delta P$ (bar)	o	$\varnothing d$	P	$\varnothing K$
50	10	4	18	32	125
65	10	4	18	32	145
80	10	8	18	32	160
100	10	8	18	32	180
125	10	8	18	32	210
150	10	8	22	32	240
200	10	8	22	33	295
250	10	12	22	35	350
300	10	12	22	37	400
350	10	16	22	37	460
400	10	16	26	41	515
450	10	20	26	45	565
500	10	20	26	46	620
600	10	20	30	49	725
700	6	24	30	56	840
750	6	24	33	58	900
800	6	24	33	59	950
900	6	28	33	62	1050
1000	4	28	36	69	1160
1100	4	32	36	72	1270
1200	4	32	39	74	1380
1300	4	32	39	80	1490
1400	4	36	42	81	1590
1500	4	36	42	82	1700

### EN 1092-2 PN10

(Fig.23)

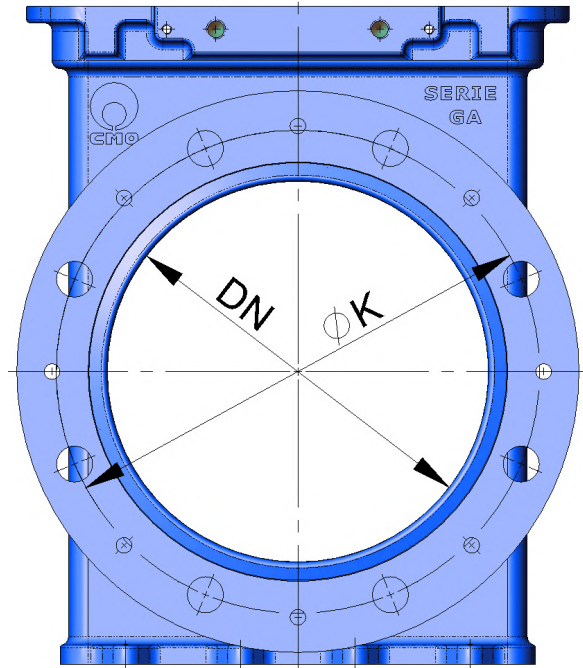

o THROUGH BOREHOLE

ANSI B16, Clase 150

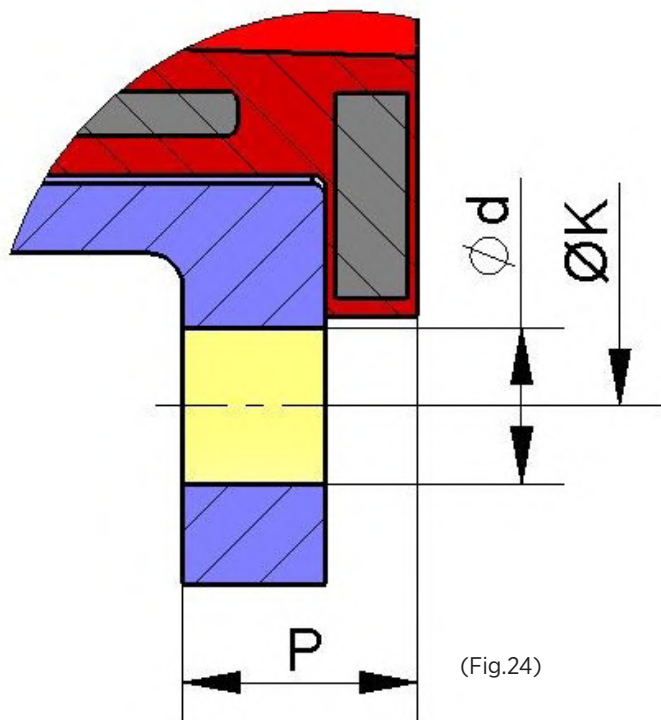

ND	$\Delta P$ (bar)	o	$\varnothing d$	PROF.	$\varnothing K$
2"	10	4	3/4"	1,28"	4,75"
2 1/2"	10	4	3/4"	1,28"	5,5"
3"	10	4	3/4"	1,28"	6"
4"	10	8	3/4"	1,28"	7,5"
5"	10	8	7/8"	1,28"	8,5"
6"	10	8	7/8"	1,28"	9,5"
8"	10	8	7/8"	1,32"	11,75"
10"	10	12	1"	1,4"	14,25"
12"	10	12	1"	1,48"	17"
14"	10	12	1 1/8"	1,48"	18,75"
16"	10	16	1 1/8"	1,64"	21,25"
18"	10	16	1 1/4"	1,8"	22,75"
20"	10	20	1 1/4"	1,84"	25"
24"	10	20	1 3/8"	1,96"	29,5"
28"	6	28	1 3/8"	2,24"	34"
30"	6	28	1 3/8"	2,32"	36"
32"	6	28	1 5/8"	2,36"	38,5"
36"	6	32	1 5/8"	2,48"	42,75"
40"	6	36	1 5/8"	2,76"	47,25"



## STANDARD VERSION

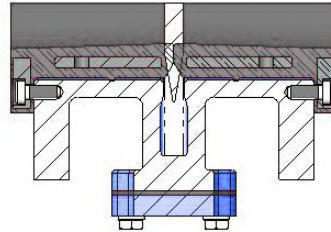
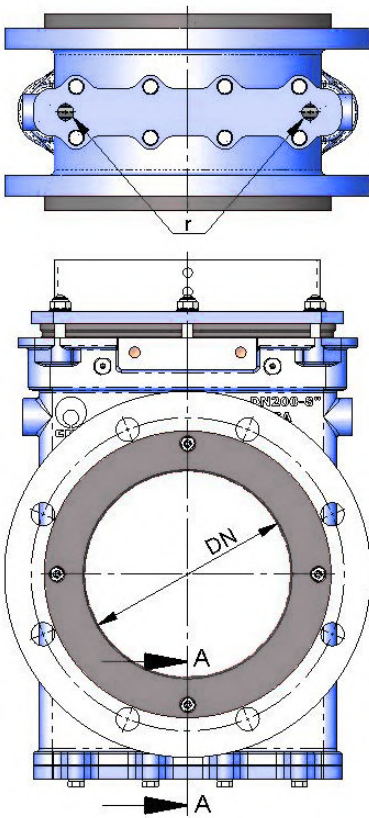

SECTION A-A

ND	r (B.S.P.)
50	1/4"
65	1/4"
80	1/4"
100	1/4"
125	1/4"
150	1/4"
200	3/8"
250	1/2"
300	1/2"
350	1/2"
400	3/4"
450	3/4"
500	3/4"
600	1"

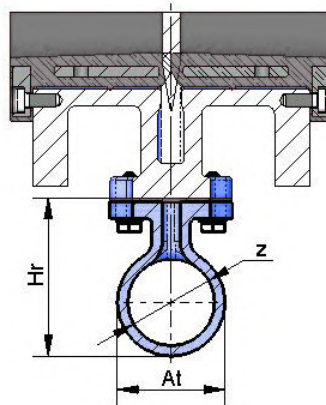
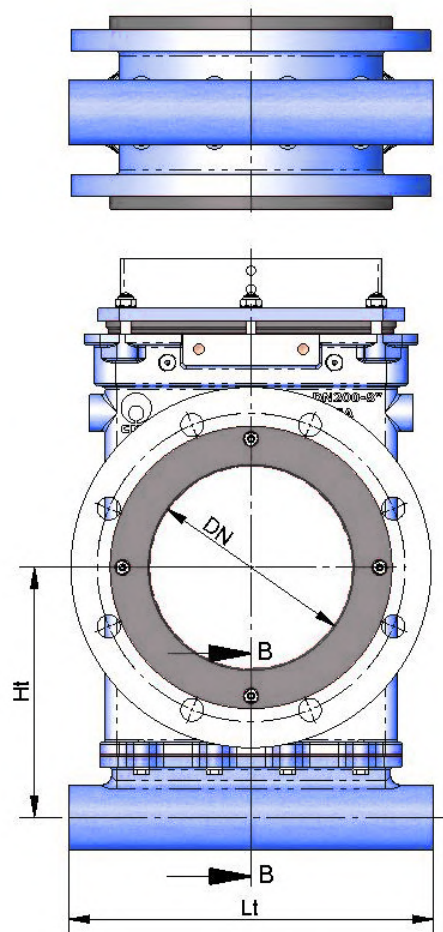

SECTION B-B

ND	Ht	Lt	At	Hr	z (B.S.P.)
50	158	185	42	68	1"
65	168	200	42	68	1"
80	174	220	42	68	1"
100	188	240	42	68	1"
125	208	265	42	73	1"
150	223	290	42	73	1"
200	272	350	62	93	1 3/4"
250	310	400	62	98	1 3/4"
300	348	450	62	98	1 3/4"
350	373	520	62	98	1 3/4"
400	403	560	62	98	1 3/4"
450	428	610	62	98	1 3/4"
500	472	690	70	107	2"
600	542	790	70	107	2"

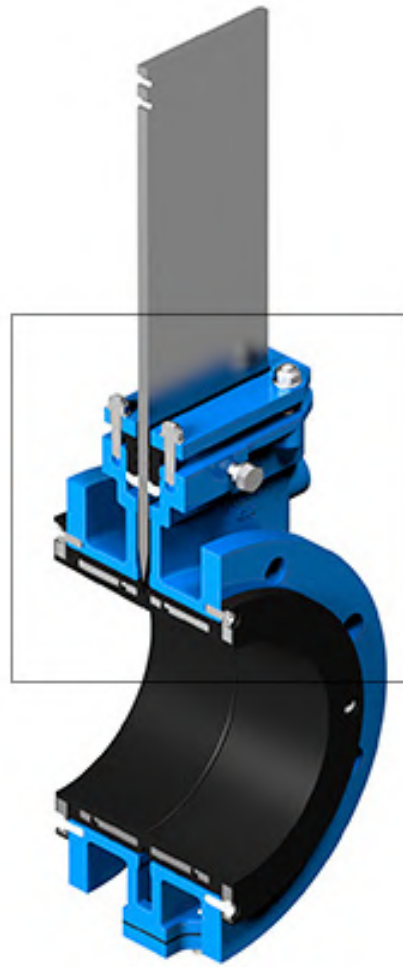
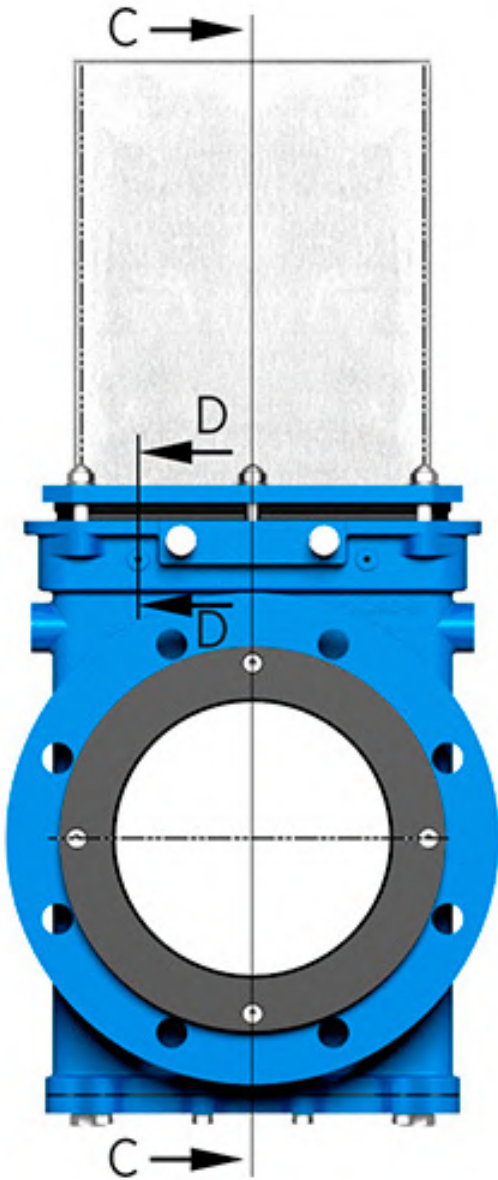

SECTION C-C

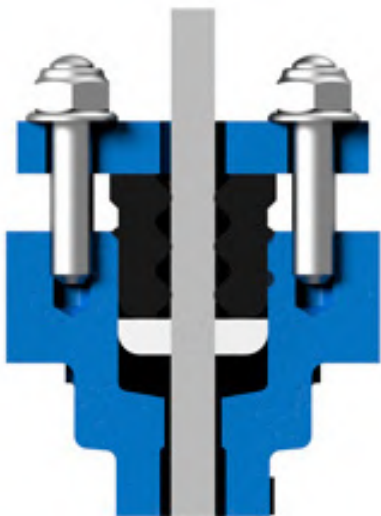

SECTION D-D

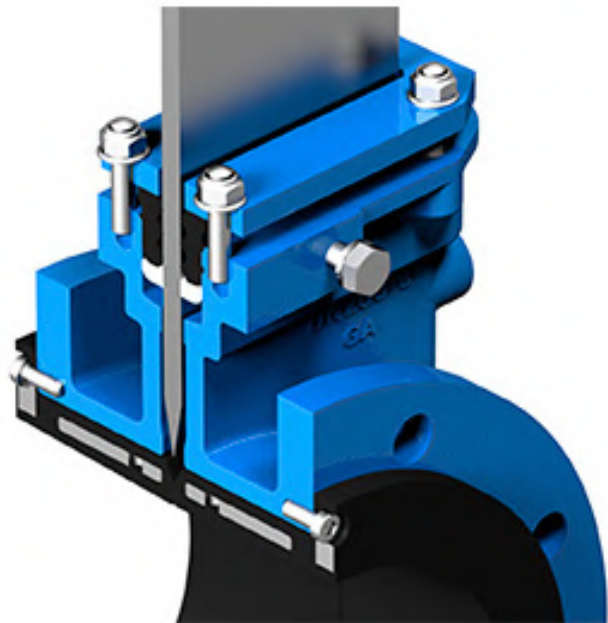

DETAIL - E