

L



## BIDIRECTIONAL KNIFE GATE VALVE

### DESCRIPTION

Two-piece cast body, joined by screws, with internal guides for smooth movement of gate during operation.

Provides high flow rates with low pressure drop.  
Various seat and packing materials available.

Face-to-face dimension in accordance with **CMO Valves** standard.

### GENERAL APPLICATIONS

This knife gate valve is suitable for liquids that contain a maximum of 20% suspended solids. It is also recommended in gravity discharge applications for solids and fine particles, because of its half-moon shape which cuts the flow and high consistency fluids.

Designed for a wide range of applications such as:

- Paper Industry
- Mining
- Chemical plants
- Food Industry
- Pumping
- Silo emptying.
- Sewage treatment

### SIZES

ND50 to ND2000 (larger sizes on request).

The pressures indicated in the table can be used in both directions of the valve.

### WORKING PRESSURE ( $\Delta P$ )

ND50 a ND150	10 bar
ND200	8 bar
ND250 a ND300	6 bar
ND350 a ND400	5 bar
ND450 a ND600	3 bar
ND700 a ND1400	2 bar

\* Other pressures, upon request

### SERIE - L

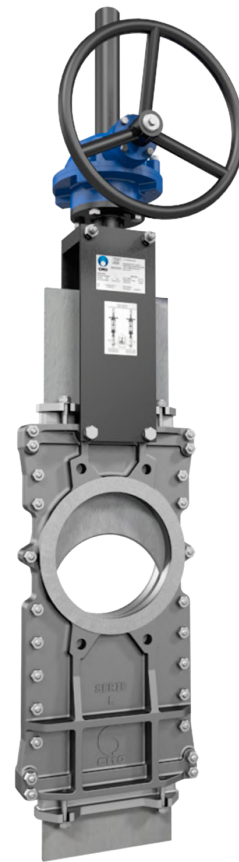

### DIRECTIVES

Pressure Equipment Directive:  
**(PED) ART 4.3 /CAT.1.**

Potential Explosive Atmospheres Directive:  
**(ATEX) CAT.3 ZONA 2 y 22 GD.**

\* For further information on categories and zones please contact the **CMO VALVES** Technical-Commercial Dept **CMO VALVES**.



### QUALITY DOSSIER

- All valves are tested hydrostatically at CMO and material and test certificates can be provided.
- Body test = working pressure x 1.5.
- Seat test = working pressure x 1.1.

## ADVANTAGES

This knife-gate valve's main characteristic is that it provides a full continuous flow. This means that in open position it produces no cavities and, therefore, there are no turbulences in the fluid. It is also referred to as a bidirectional through-going gate valve or through conduit knife gate valve. The valve's body is composed of two parts or halves. The internal surface of both parts is fully machined and they are assembled with screws to form a solid block.

The gate in the stainless steel version slides smoothly inside the body thanks to the nylon RCH 1000 slides inserted inside both parts of the body. The stem protection hood is independent from the handwheel securing nut, this means the hood can be disassembled without the need to release the handwheel. This advantage allows regular maintenance operations to be performed, such as lubricating the stem, etc.

The stem on the CMO valve is made of 18/8 stainless steel. This is another added advantage, as some manufacturers produce it with 13% chrome and it gets rusty very quickly. The handwheel is made of GJS-500 nodular cast iron. Some manufacturers produce them in normal cast iron which can lead to breakages in the event of very high operating torque or knocks.

The yoke is has a compact design with the bronze actuator nut protected in a sealed and lubricated box. This makes it possible to move the valve with a key, even without the handwheel (in other manufacturers' products this is not possible).

The pneumatic actuator's upper and lower covers are made of GJS-400 nodular cast iron, making them highly shock resistant. This characteristic is essential in pneumatic actuators.

The pneumatic cylinder's o-ring seals are commercial products and can be purchased worldwide. This means it is not necessary to contact **CMO Valves** every time a seal is required.

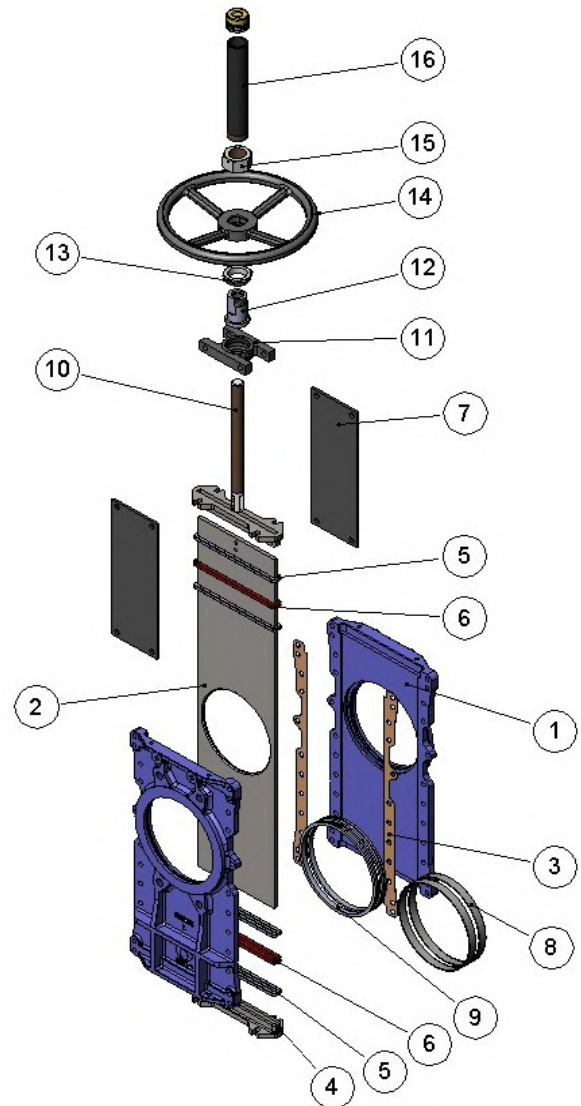

STANDARD COMPONENTS LIST		
COMPONENT	CAST IRON VERSION	STAINLESS STEEL VERSION
1 BODY	GJL-250	CF8M
2 GATE	AISI304	AISI316
3 SEAL		CARDBOARD
4 PACKING GLAND	GJS-500	CF8M
5 PACKING		SYNT + PTFE
6 SEAL		EPDM
7 SUPPORT PLATES		S275JR
8 RING		AISI316
9 SEAT		EPDM
10 STEM		AISI303
11 BRIDGE		STEEL
12 STEM NUT		BRONZE
13 CHECK NUT		ST44.2 + ZINC
14 HANDWHEEL		NODULAR CAST IRON
15 NUT		STEEL
16 CAP		STEEL

Table 1

**Note:** The stainless steel valves have slides on each side of the body to avoid friction and possible seizure of the valve, these slides are made of RCH1000.

## DESIGN

### 1. BODY

Cast iron body with reinforcements, composed of two parts joined by screws, the stainless steel version has internal nylon RCH1000 slides for the smooth movement of the gate, the GJL-250 versions do not require slides. The internal surface of both parts is fully machined and they are assembled with screws to form a solid block. Provides a full continuous flow. This means that in open position it produces no cavities and, therefore, there are no turbulences in the fluid and the load loss is minimal. For diameters greater than ND1200 the body is machine-welded with the necessary reinforcements to resist the maximum working pressure. The standard manufacturing materials are GJL-250 cast iron and CF8M stainless steel. Other materials, such as GJS-500 nodular cast iron, A216WCB carbon steel and stainless steel alloys (AISI316Ti, Duplex, 254SMO, Uranus B6...) are available on request. As standard, iron or carbon steel valves are painted with an anti-corrosive protection of 80 microns of EPOXY (colour RAL 5015). Other types of anti-corrosive protections are available on request.

### 2. GATE

The standard manufacturing materials are AISI304 stainless steel in valves with iron body and AISI316 stainless steel in valves with CF8M body. Other materials or combinations can be supplied on request. The gate is polished on both sides to provide a smooth contact surface with the resilient seat. At the same time, the gate is rounded to prevent the seat from being cut. Different degrees of polishing, anti-abrasion treatments and modifications are available to adapt the valves to the customer's requirements.

### 3. SEAT:

The following six types of seats are available according to the working application:

**Seat 1:** Metal / metal seat. This type of seat does not include any kind of resilient seat and the estimated leakage (considering water as the test fluid) is 1.5% of the pipe flow.

**Seat 2:** Standard soft-seated valve. This type of seat includes a resilient seat which is fixed to the inside of the body via an AISI316 stainless steel retaining ring. As this valve is bidirectional it includes two watertight seals.

**Seat 3:** Soft-seated valve with reinforced socket. This type of seat includes a resilient seat which is fixed to the inside of the body via an AISI316 stainless steel retaining ring with two functions (to protect the valve from abrasion and clean the gate when working with solids that stick to it). As this valve is bidirectional it includes two watertight seals and two reinforced rings.

**Seats 4, 5 and 6:** The same as seats 1, 2 and 3 but including a deflector. The deflector is a cone-shaped ring located at the valve's entrance with two functions (to protect the valve from abrasion and guide the flow to the centre of the valve's hole). Three materials are available for the reinforced socket and the deflector (CA-15 steel, CF8M and Ni-hard).

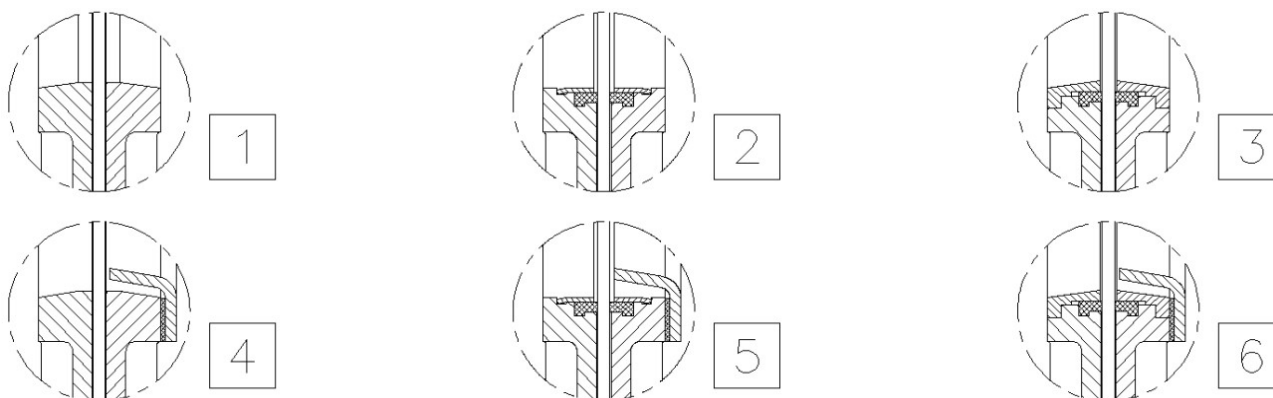

## Resilient seat materials

### EPDM

This is the standard resilient seat fitted on CMO valves. It can be used in many applications, however, it is generally used for water and products diluted in water at temperatures no higher than 90°C\*. It can also be used with abrasive products and it provides the valve with 100% watertight integrity.

### VITON

Suitable for corrosive applications and continuous high temperatures of up to 190°C and peaks of 210°C. It provides the valve with 100% watertight integrity.

### NITRILE

It is used in fluids containing fats or oils at temperatures no higher than 90°C\*. It provides the valve with 100% watertight integrity.

### SILICONE

Mainly used in the food industry and for pharmaceutical products with temperatures no higher than 200°C. It provides the valve with 100% watertight integrity.

### PTFE

Suitable for corrosive applications and pH between 2 and 12. Does not provide the valve with 100% watertight integrity. Estimated leakage: 0.5% of the tube flow.

**Note:** In some applications other types of resilient materials are used, such as hypalon, butile or natural rubber. Please contact us if you require one of these materials.

## 4. PACKING

The standard packing is composed of three lines with a specially designed EPDM O-ring in the middle which provides watertight integrity between the body and the gate, preventing any type of leakage to the atmosphere. It is located in an easily accessible place and can be replaced without dismantling the valve from the pipeline. Below we indicate various types of packing available according to the application in which the valve is located:

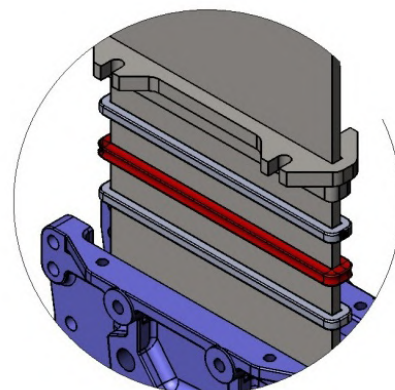

### GREASED COTTON

**(Recommended for hydraulic services)** This packing is composed of braided cotton fibres soaked in grease both inside and out. It is for general use in hydraulic in both pumps and valves.

### DRY COTTON

This packing is composed of cotton fibres. It is for general use in hydraulic applications with solids.

### COTTON + PTFE

This packing is composed of braided cotton fibres soaked in PTFE both inside and out. It is for general use in hydraulic applications in both pumps and valves.

### CERAMIC FIBRE

This packing is composed of ceramic material fibres. Its main applications are with air or gas at high temperatures and low pressures.

### SYNTHETIC + PTFE

This packing is composed of braided synthetic fibres soaked in PTFE both inside and out. It is for general use in hydraulic applications in both pumps and valves and in all types of fluids, especially corrosive ones, including concentrated and oxidising oils. It is also used in liquids with solid particles in suspension.

### GRAPHITE:

This packing is composed of high-purity graphite fibres. A diagonal braiding system is used and it's impregnated with graphite and lubricant which helps to reduce porosity and improve operation.

It has a wide range of applications as graphite is resistant to steam, water, oils, solvents, alkali and most acids.

SEAT/SEALS			PACKING			
MATERIAL	T <sup>º</sup> MÁX (°C)	APPLICATIONS	MATERIAL	P (bar)	T <sup>º</sup> MÁX (°C)	pH
EPDM (E)	90 *	Mineral acids and oils	Greased cotton	10	100	6-8
Nitrile (N)	90 *	Hydrocarbons, oils and greases	Dry cotton (AS)	0,5	100	6-8
Vitón (V)	200	Hydrocarbons and solvents	Synthetic + PTFE	100	-200+270	0-14
Silicone (S)	200	Food Products	Graphite	40	650	0-14
* ⇨ EPDM y Nitrilo: es posible hasta T <sup>º</sup> Max.: 120°C bajo pedido.			Ceramic Fibre	0,3	1400	0-14

Table 2

**Note:** More details and other materials on request.



## 5. STEM

The stem on the CMO valve is made of 18/8 stainless steel. This characteristic provides high resistance and excellent corrosion-resistant properties. The valve design can be rising stem or non-rising stem. When rising stem is required a stem hood is supplied to protect the stem from contact with dust and dirt, as well as keeping it lubricated

## 6. PACKING GLAND

The packing gland allows uniform force and pressure to be applied to the packing to ensure watertight integrity. As standard, valves with cast iron body include GJS-450 packing glands, whilst valves with stainless steel body have CF8M packing glands.

## 7. ACTUATORS

All types of actuators can be supplied, with the advantage that the design is fully interchangeable. This design allows the customer to change the actuators themselves and normally no extra assembly accessories are required. In the event any accessory is required, **CMO Valves** will supply it.

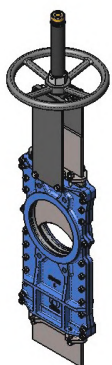
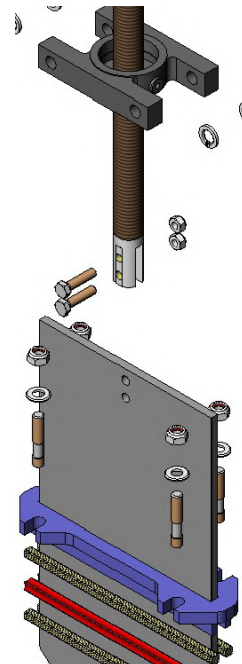

Handwheel with rising stem

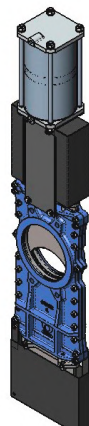

Pneumatic cylinder

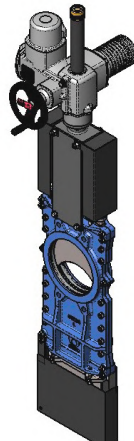

Electric actuator

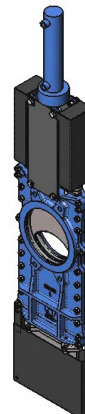

Hydraulic cylinder

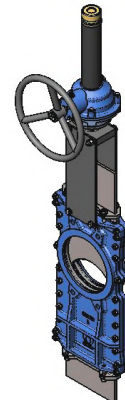

Gear Box

The chainwheel and gear box actuators are also available with non-rising stem. The pneumatic actuators can be single or double acting, and the single acting ones can in turn be open spring or close spring.

### Manual Actuators

Handwheel with rising stem / **non**-rising stem

Level / Chainwheel

Gear Box / Others, (square nut)

### Automatic Actuators

Electric actuator

Pneumatic cylinder

Hydraulic cylinder

## ACCESSORIES AND OPTIONS

Different accessories are available to adapt the valve to specific working conditions such as:

**MIRROR POLISHED GATE** The mirror polished gate is especially recommended in the food industry and, as standard, in applications in which solids can stick to the gate. It is an alternative to ensure the solids slide off and do not stick to the gate.

**PTFE LINED GATE** As with the mirror polished gate, it improves the valve's resistance to products that can stick to the gate.

**STELLITED GATE** Stellite is added to the gate's internal circle to protect it from abrasion.

**SCRAPER IN THE PACKING** It cleans the gate during the opening movement and prevents possible damage to the packing.

**AIR INJECTION IN THE PACKING GLAND** By injecting air in the packing, an air chamber is created which improves the water-tight integrity.

**HEATING JACKET** Recommended in applications in which the fluid can harden and solidify inside the valve's body. An external jacket keeps the body temperature constant, preventing the fluid from solidifying.

**FLUSHING HOLES IN BODY (FIG. 8)** Several holes are drilled in the body to flush air, steam or other fluids out in order to clean the valve seat before sealing.

**MECHANICAL LIMIT SWITCHES, INDUCTIVE SWITCHES AND POSITIONERS** Limit switches or inductive switches are installed to indicate precise valve position, as well as positioners to indicate continuous position.

**SOLENOID VALVES** For air distribution to pneumatic actuators.

**CONNECTION BOXES, WIRING AND PNEUMATIC PIPING** Fully assembled units can be supplied with all the necessary accessories.

**STROKE LIMITING MECHANICAL STOPS - MECHANICAL LOCKING DEVICE** Allows the valve to be mechanically locked in a set position for long periods of time.

**EMERGENCY MANUAL ACTUATOR (HAND WHEEL /GEAR BOX)** Allows manual operation of the valve in the event of power or air failure.

**TRIANGULAR (V-NOTCH) AND PENTAGONAL DIAPHRAGM WITH INDICATION RULE (FIG. 7)** Recommended for application in which it is necessary to regulate the flow, it allows flow control according to the valve's opening percentage.

**INTERCHANGEABLE ACTUATORS** All actuators are easily interchangeable.

**ACTUATOR OR YOKE SUPPORT** Made of EPOXY-coated steel (or stainless steel on request), its robust design gives it great rigidity in order to resist the most adverse operation conditions.

**EPOXY COATING** All cast iron and carbon steel bodies and components on **CMO valves** are EPOXY coated, giving the valves great resistance to corrosion and an excellent finish. CMO's standard colour is blue, RAL-5015.

### GATE SAFETY PROTECTION

In accordance with European Safety Standards ("EC" marking), CMO automated valves are equipped with gate guards, to prevent any objects from being accidentally caught in the gate.

### BONNET (FIG. 8)

The bonnet provides total watertight integrity to the outside, reducing the packing maintenance required.

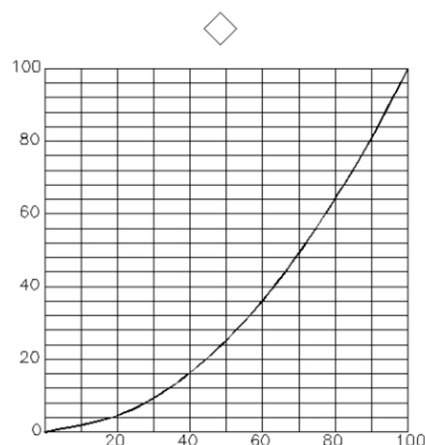
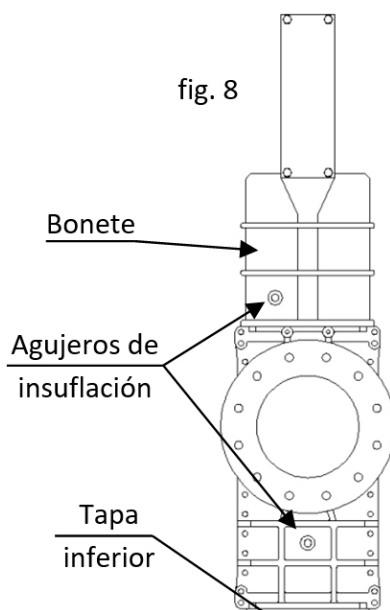

**VERTICAL: % MAXIMO DE CAUDAL**  
**HORIZONTAL: % DE APERTURA DE LA VALV.**  
 (diafragma cuadrangular)

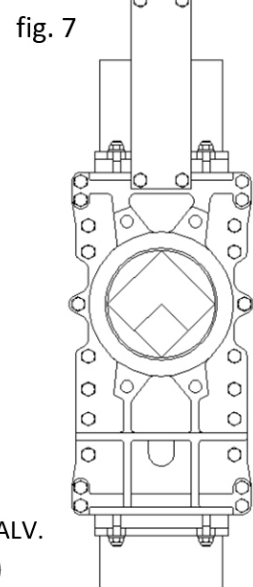

## TYPES OF EXTENSION

HANDWHEEL

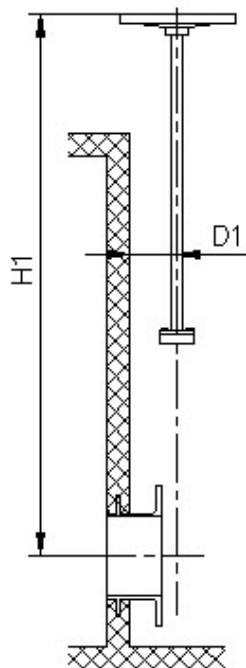

HANDWHEEL

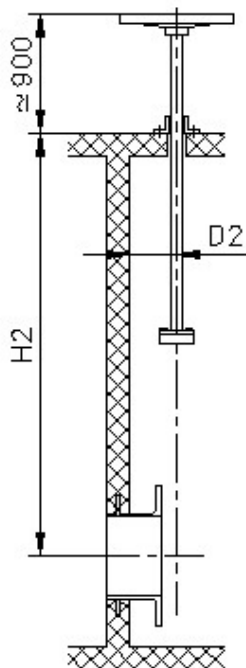

HANDWHEEL

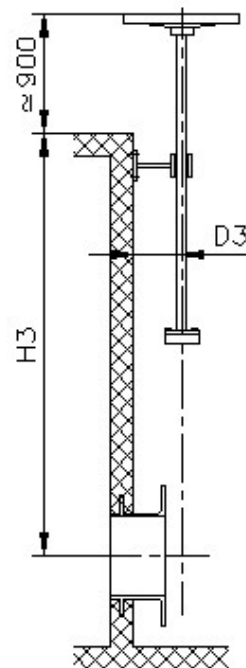

Square + T Box

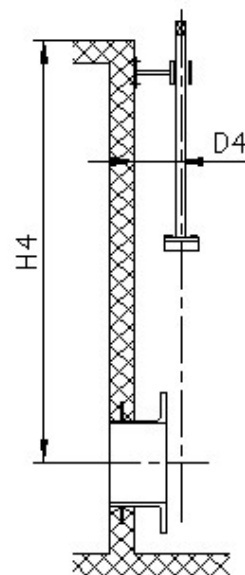

Adaptation to actuator

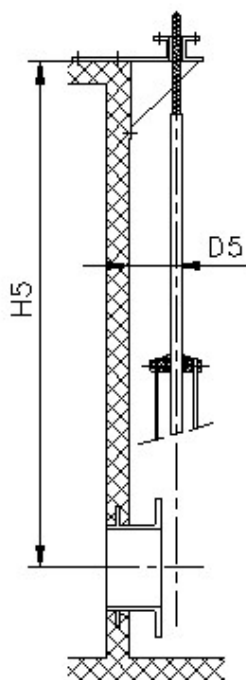

5- Rising stem  
+ bracket support  
+ adaptation to actuator

HANDWHEEL

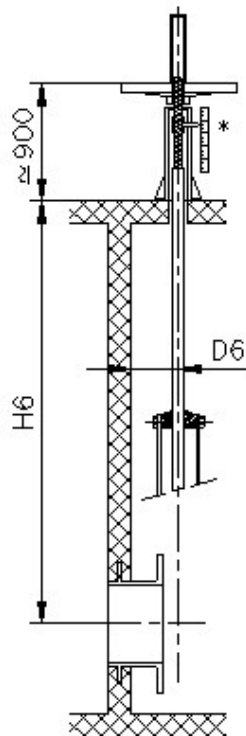

6- Rising stem  
+ stand

HANDWHEEL

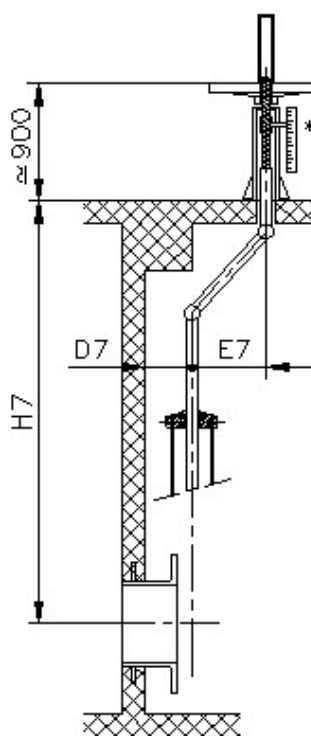

7- Non-rising stem  
+ stand  
+ two universal joints.

HANDWHEEL

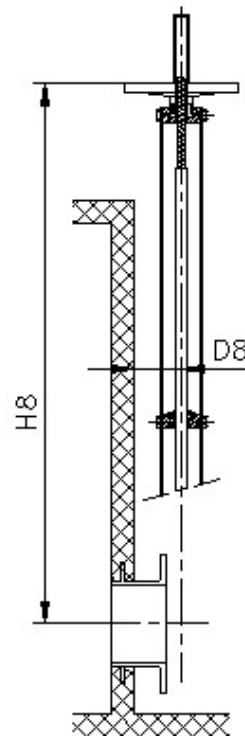

8- Rising stem  
+ extended plates.

**Nota:** It is possible to fit a position indicator on the floor stand.

## HANDWHEEL WITH RISING STEM

The definition variables are as follow:

- **B = Max. width** of the valve (without actuator).
- **D = Max. height** of the valve (without actuator).
- **C = maximum** length when the gate is centred.

### OPTIONS:

- Locking devices.
- Extensions: stand, pipe, plates...
- ND higher than those give in the table

### ACTUATOR INCLUDING:

- Handwheel.
- Stem.
- Nut.
- Stem protection hood.

### AVAILABLE:

- Standard ND50 a ND1200.
- Other ND on request
- The weights are approximate and vary according to the material ar valve's accessories.
- From DN600 the actuator is with gears box.

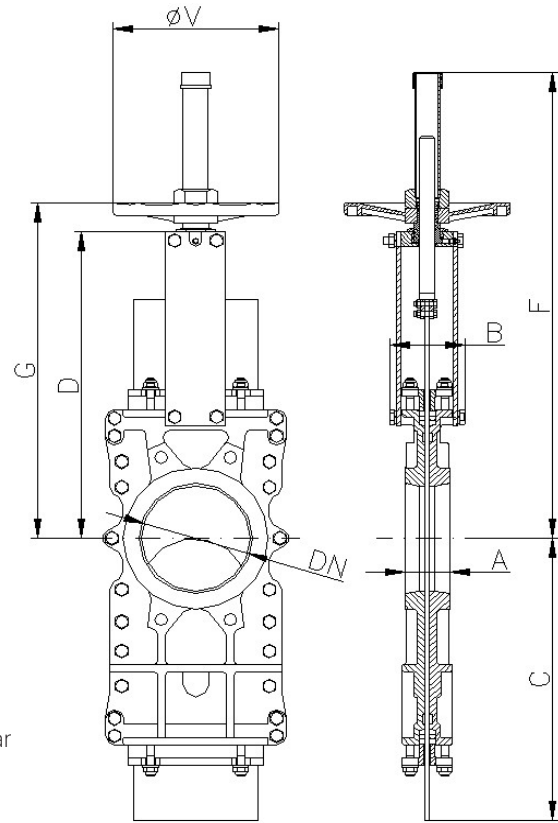

ND	ΔP (Kg/cm <sup>2</sup> )	DRAW (Nw)	TORQUE (Nm)	A	B	C	D	F	G	øV	Weight (kg.)
50	10	894	2.1	40	91	225	243	412	282	225	12
65	10	1508	3.5	40	91	265	269	437	308	225	13
80	10	2281	5.2	50	91	310	293	462	332	225	17
100	10	3561	8.2	50	91	370	334	503	373	225	19
125	10	5565	13	50	101	430	367	586	407	225	28
150	10	6419	15	60	101	495	419	638	458	225	38
200	8	10020	29	60	118	630	525	816	578	325	54
250	6	11230	32.5	70	118	770	620	1017	679	325	88
300	6	16210	47	70	118	895	704	1117	779	380	112
350	5	17740	70	96	290	1050	780	1337	906	450	163
400	5	23260	92	100	290	1185	855	1443	1012	450	235
450	3	22260	89	106	290	1320	975	1629	1098	450	368
500	3	27470	110	110	290	1455	1064	1741	1210	450	471
600	3	39850	160	110	290	1720	1244	2047	1416	450	532
700	2	36880	212	110	320	1995	1425	--	--	--	936
800	2	48980	285	110	320	2230	1615	--	--	--	N.D.
900	2	61230	353	110	320	2465	1823	--	--	--	N.D.
1000	2	77690	457	110	320	2620	1992	--	--	--	N.D.
1100	2	95506	674	150	340	3030	2217	--	--	--	N.D.
1200	2	113710	802	150	340	3250	2351	--	--	--	N.D.

N.G.: Weight not given

Table 3



## HANDWHEEL WITH NON-RISING STEM

Suitable when no size limitations exist.

The definition variables are as follow:

- **B = Max. width** of the valve (without actuator).
- **D = Max. height** of the valve (without actuator).
- **C = maximum** length when the gate is centred.

**OPTIONS:**

- Square nut.
- Locking devices.
- Extensions: stand, pipe, plates...
- ND higher than those give in the table

**ACTUATOR INCLUDING:**

- Handwheel.
- Stem.
- Nut.
- Stem protection hood.

**AVAILABLE:**

- Standard ND50 a ND1200.
- Other ND on request.
- The weights are approximate and vary according to the material and the valve's accessories..
- From DN600 the actuator is with gears box.

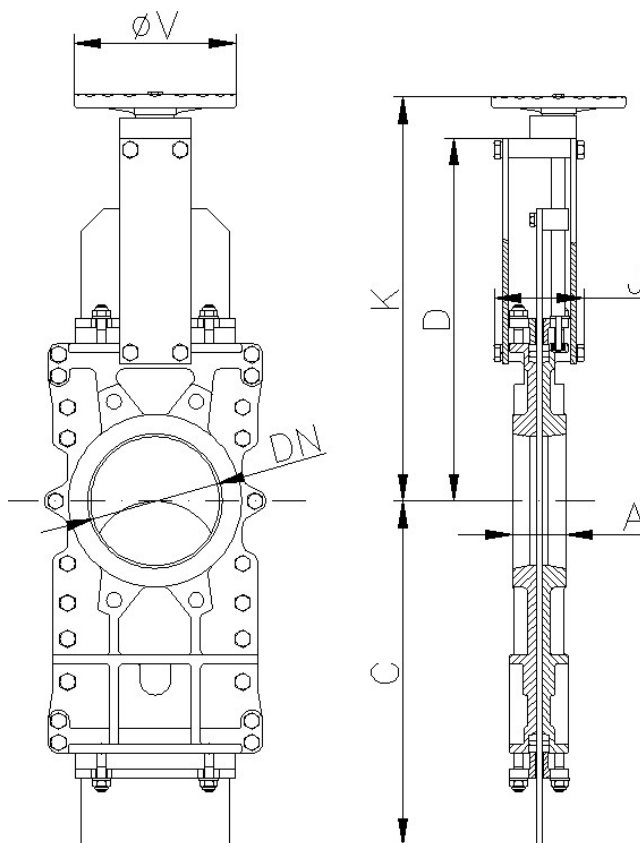

ND	ΔP (Kg/cm2)	DRAW (Nw)	TORQUE (Nm)	A	C	D	J	K	øV	Weight (kg.)
50	10	894	2.1	40	225	243	101	277	225	12
65	10	1508	3.5	40	265	269	101	304	225	13
80	10	2281	5.2	50	310	293	101	330	225	17
100	10	3561	8.2	50	370	334	101	370	225	19
125	10	5565	13	50	430	367	111	402	225	28
150	10	6419	15	60	495	419	111	454	225	38
200	8	10020	29	60	630	525	128	578	325	54
250	6	11230	32.5	70	770	620	128	679	325	88
300	6	16210	47	70	895	704	128	779	380	112
350	5	17740	70	96	1050	780	305	860	450	163
400	5	23260	92	100	1185	855	305	981	450	235
450	3	22260	89	106	1320	975	305	1067	450	368
500	3	27470	110	110	1455	1064	305	1179	450	471
600	3	39850	160	110	1720	1244	305	1386	450	532
700	2	36880	212	110	1995	1425	335	--	--	936
800	2	48980	285	110	2230	1615	335	--	--	N.D.
900	2	61230	353	110	2465	1823	335	--	--	N.D.
1000	2	77690	457	110	2620	1992	335	--	--	N.D.
1100	2	95506	674	150	3030	2217	355	--	--	N.D.
1200	2	113710	802	150	3250	2351	355	--	--	N.D.

N.G.: Weight not given

Table 4

## CHAINWHEEL

- Widely used in raised installations with difficult access, the handwheel is fitted in vertical position.

The definition variables are as follow:

• **A = Max. width** of the valve (without actuator).

• **B = Max. height** of the valve (without actuator).

• **C = maximum** length when the gate is centred.

### OPTIONS:

- Locking devices.
- Extensions: stand, pipe, plates...
- Non-rising stem.
- ND higher than those give in the table

### ACTUATOR INCLUDING:

- Handwheel.
- Stem.
- Nut.
- Stem protection hood.

### AVAILABLE SIZES

- Santdard DN50 a DN1200. Otros DN bajo consulta.
- From ND 600, the valves are with gear box, see \* in the table.

- The weights are approximate and vary according to the material and tl valve's accessories.

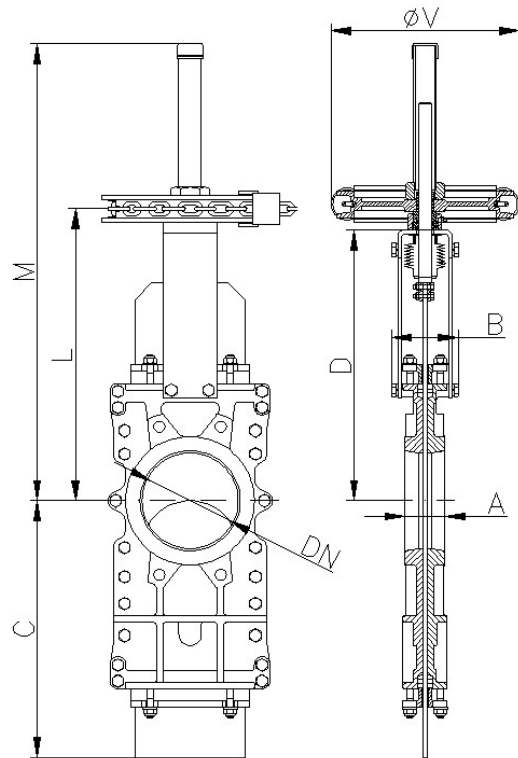

ND	ΔP (Kg/cm <sup>2</sup> )	DRAW (Nw)	TORQUE (Nm)	A	B	C	D	L	M	øV	Weight (kg.)
50	10	894	2.1	40	91	225	243	294	437	225	12
65	10	1508	3.5	40	91	265	269	319	464	225	13
80	10	2281	5.2	50	91	310	293	346	490	225	17
100	10	3561	8.2	50	91	370	334	386	530	225	19
125	10	5565	13	50	101	430	367	420	613	225	28
150	10	6419	15	60	101	495	419	471	665	225	38
200	8	10020	29	60	118	630	525	602	849	300	54
250	6	11230	32.5	70	118	770	620	697	1050	300	88
300	6	16210	47	70	118	895	704	797	1150	300	112
350	5	17740	70	96	290	1050	780	918	1398	402	163
400	5	23260	92	100	290	1185	855	998	1504	402	235
450	3	22260	89	106	290	1320	975	1078	1690	402	368
500	3	27470	110	110	290	1455	1064	1201	1802	402	471
600	3	39850	160	110	290	1720	1244	1329	2108	402	532
700	2	36880	212	110	320	1995	1425	1606	2406	402*	936
800	2	48980	285	110	320	2230	1615	1820	2720	402*	N.D.
900	2	61230	353	110	320	2465	1823	2053	3053	402*	N.D.
1000	2	77690	457	110	320	2620	1992	2257	3337	402*	N.D.
1100	2	95506	674	150	340	3030	2217	2546	3676	402*	N.D.
1200	2	113710	802	150	340	3250	2351	2836	4016	402*	N.D.

N.G.: Weight not given

Table 5

## LEVER

- It is a fast actuator.

The definition variables are as follow:

- A = Max. width of the valve (without actuator).
- B = Max. height of the valve (without actuator).
- C = maximum length when the gate is centred.

### ACTUATOR INCLUDING:

- Lever.
  - Rod.
  - Guide bearing.
  - External limiting switches to maintain the position.
- Available: ND50 to ND300, other ND on request.
  - The weights are approximate and vary according to the material valve's accessories.

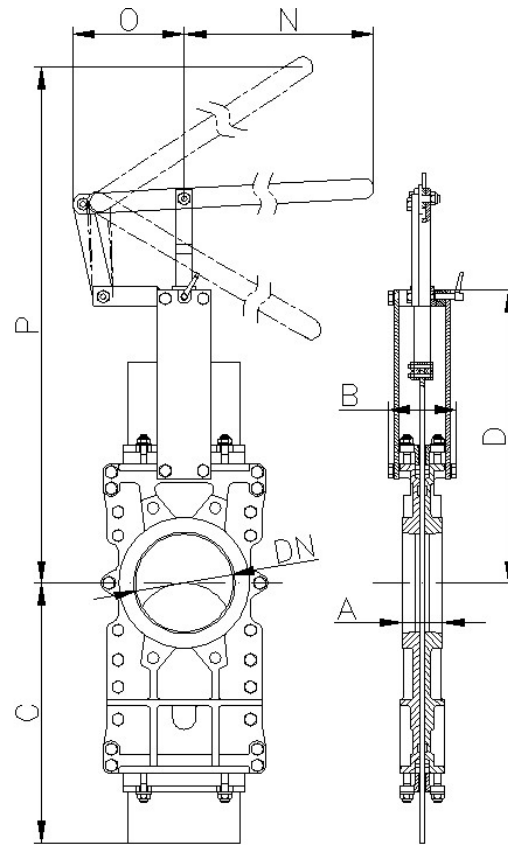

DN	$\Delta P$ (Kg/cm <sup>2</sup> )	DRAW (Nw)	A	B	C	D	N	O	P	Weight (kg.)
50	10	894	40	91	225	243	325	155	504	13
65	10	1508	40	91	265	269	325	155	526	14
80	10	2281	50	91	310	293	325	155	549	18
100	10	3561	50	91	370	334	325	155	605	20
125	10	5565	50	101	430	367	425	155	902	29
150	10	6419	60	101	495	419	425	155	956	39
200	8	10020	60	118	630	525	620	290	1027	55
250	6	11230	70	118	770	620	620	290	1416	89
300	6	16210	70	118	895	704	620	290	1525	113

Table 6

## GEARBOX

It is recommended for ND greater than 600.

The definition variables are as follow:

- **A = Max. width** of the valve (without actuator).
- **B = Max. height** of the valve (without actuator).
- **C = maximum** length when the gate is centred.

### OPTIONS:

- Locking devices.
- Extensions: stand, pipe, plates...
- Non-rising stem

### ACTUATOR INCLUDING:

- Cone-shaped gear box
- Stem
- Yoke
- Handwheel

### AVAILABLE:

- ND50 to ND1200, other ND on request.
- The weights are approximate and vary according to the material and the valve's accessories..

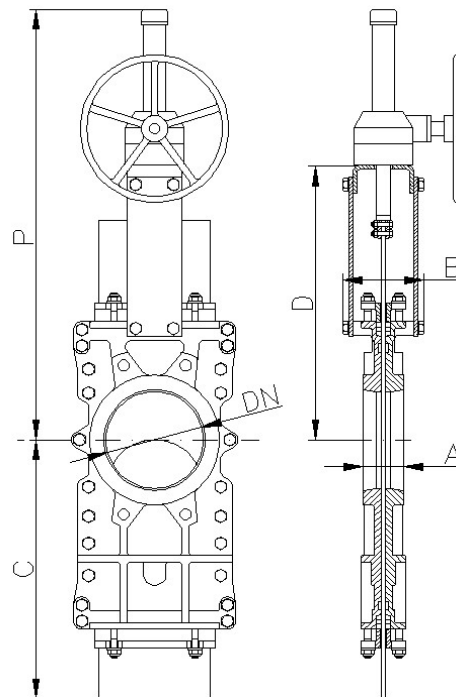

ND	$\Delta P$ (Kg/m <sup>2</sup> )	DRAW(Nw)	TORQUE (Nm)	A	B	C	P	D	Weight (kg.)
50	10	894	2.1	40	91	225	540	243	22
65	10	1508	3.5	40	91	265	566	269	23
80	10	2281	5.2	50	91	310	591	293	27
100	10	3561	8.2	50	91	370	631	334	28
125	10	5565	13	50	101	430	665	367	37
150	10	6419	15	60	101	495	717	419	47
200	8	10020	29	60	118	630	943	525	76
250	6	11230	32.5	70	118	770	1037	620	111
300	6	16210	47	70	118	895	1171	726	133
350	5	17740	70	96	290	1050	1318	780	163
400	5	23260	92	100	290	1185	1393	855	247
450	3	22260	89	106	290	1320	1662	975	386
500	3	27470	110	110	290	1455	1752	1064	495
600	3	39850	160	110	290	1720	1981	1244	552
700	2	36880	212	110	320	1995	2320	1425	956
800	2	48980	285	110	320	2230	2610	1615	N.D.
900	2	61230	353	110	320	2465	2913	1823	N.D.
1000	2	77690	457	110	320	2620	3206	1992	N.D.
1100	2	95506	674	150	340	3030	3777	2217	N.D.
1200	2	113710	802	150	340	3250	4042	2351	N.D.
1300	2	133563	943	150	390	3430	4382	2882	N.D.
1400	2	157280	1298	150	390	3680	4852	3250	N.D.
1500	2	180712	1493	170	426	3930	5217	3517	N.D.
1600	2	205780	1904	170	426	4272	5575	3775	N.D.
1700	2	236498	2214	190	440	4615	5908	4008	N.D.
1800	2	264860	2477	190	440	4886	6242	4242	N.D.
1900	2	299502	3213	210	480	5158	6490	4390	N.D.
2000	2	331260	3549	210	480	5430	6740	4540	N.D.

N.G.: Weight not given

Table 7



## DOUBLE-ACTING PNEUMATIC CYLINDER

- The air supply pressure to the pneumatic cylinder is a minimum of 6 Kg/cm<sup>2</sup> and a maximum of 10 Kg/cm<sup>2</sup>, the air must be dry and lubricated.

- For ND50 to ND200 valves, the cylinder's jacket and covers are made of aluminium, the rod of AISI304, the piston of rubber-coated steel and the O-ring seals are made of nitrile.

- For valves larger than ND200 the covers are made of nodular cast iron or carbon steel.

- On request, we can also supply the actuator made entirely of stainless steel, especially for installation in corrosive atmospheres.

• **A = Max. width** of the valve (without actuator).  
 • **B = Max. height** of the valve (without actuator).  
 • **C = maximum** length when the gate is centred.

**AVAILABLE:**

- ND50 to ND2000, other ND on request.  
 The weights are approximate and vary according to the material and the valve's accessories..

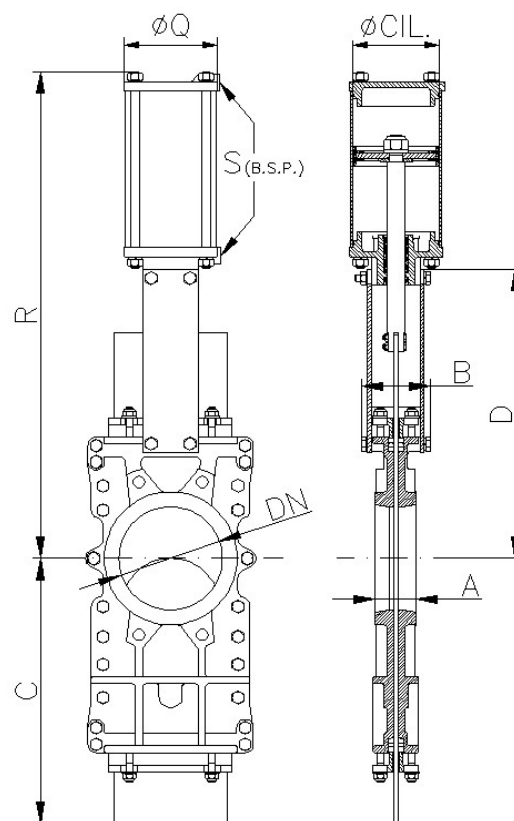

ND	ΔP (Kg/cm <sup>2</sup> )	DRAW (Nw)	A	B	C	D	R	ø CIL	ø Vast.	ø Q	S (B.S.P.) (B.S.P.)	Weight (kg.)
50	10	894	40	91	225	243	416	80	20	90	1/4"	12
65	10	1508	40	91	265	269	456	80	20	90	1/4"	13
80	10	2281	50	91	310	293	497	80	20	90	1/4"	19
100	10	3561	50	91	370	334	561	100	20	110	1/4"	19
125	10	5565	50	101	430	367	636	125	25	135	1/4"	33
150	10	6419	60	101	495	419	717	125	25	135	1/4"	43
200	8	10020	60	118	630	525	874	160	30	170	1/4"	65
250	6	11230	70	118	770	620	1030	200	30	215	3/8"	104
300	6	16210	70	118	895	704	1160	200	30	215	3/8"	126
350	5	17740	96	290	1050	780	1364	250	40	270	3/8"	200
400	5	23260	100	290	1185	855	1482	250	40	270	3/8"	281
450	3	22260	106	290	1320	975	1662	300	45	382	1/2"	427
500	3	27470	110	290	1455	1064	1802	300	45	382	1/2"	540
600	3	39850	110	290	1720	1244	2081	300	45	444	1/2"	609
700	2	36880	110	320	1995	1425	2400	350	45	444	1/2"	1054
800	2	48980	110	320	2230	1615	2693	350	45	444	1/2"	N.D.
900	2	61230	110	320	2465	1823	3037	400	50	508	1/2"	N.D.
1000	*	*	110	320	2620	1992	3306	400	50	508	1/2"	N.D.
1100	*	*	150	340	3030	2217	3587	400	50	508	1/2"	N.D.
1200	*	*	150	340	3250	2351	3868	400	50	508	1/2"	N.D.

\* ⇨ Consult

N.G.: Weight not given

Table 8

## SINGLE-ACTING PNEUMATIC CYLINDER

- The air supply pressure to the pneumatic cylinder is a minimum of 6 Kg/cm<sup>2</sup> and a maximum of 10 Kg/cm<sup>2</sup>, the air must be dry and lubricated.
- Available for opening or closing in case of air supply failure (spring opening or closing).
- The jacket is made of aluminium, the covers of nodular cast iron or carbon steel, the rod of AISI304, the piston of rubber-coated steel and the O-ring seals of nitrile.
- The actuator design is spring activated for valves with diameters up to ND300. For larger diameters the actuator contains a double-acting cylinder and an air tank which stores the volume of air necessary to perform the last movement in the event of a fault.

The definition variables are as follow:

- **A = Max. width** of the valve (without actuator).
- **B = Max. height** of the valve (without actuator).
- **C = maximum** length when the gate is centred.

### AVAILABLE

- From ND50 to ND2000, other ND on request.
- The weights are approximate and vary according to the material and the valve's accessories.

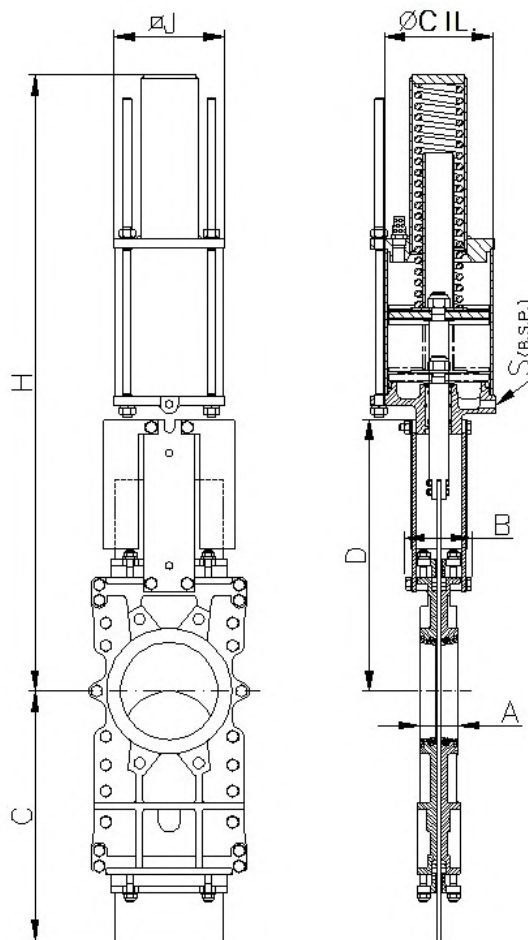

**Note:** Please see the “CMO Pneumatic Actuators” catalogue if you require further information.

ND	ΔP (Kg/cm <sup>2</sup> )	DRAW (Nw)	A	B	C	D	H	ø J	ø CIL	ø VAST	S (B.S.P)	Weight (kg.)
50	10	894	40	91	225	243	781	135	125	25	1/4"	12
65	10	1508	40	91	265	269	806	135	125	25	1/4"	13
80	10	2281	50	91	310	293	833	135	125	25	1/4"	19
100	10	3561	50	91	370	334	873	170	125	25	1/4"	19
125	10	5565	50	101	430	367	909	215	160	30	1/4"	33
150	10	6419	60	101	495	419	960	215	160	30	1/4"	43
200	8	10020	60	118	630	525	1355	270	200	30	3/8"	65
250	6	11230	70	118	770	620	1844	382	250	40	3/8"	104
300	6	16210	70	118	895	704	2005	382	250	40	3/8"	126

Table 9

## ELECTRIC ACTUATOR

This actuator is automatic and includes the following parts:

- Electric motor - Stem - Yoke

The electric motor includes:

- Emergency manual handwheel.
- Limit switches.
- Torque switches.

### OPTIONS:

Different types and brands.

- Non-rising stem.
- ISO 5210 / DIN 3338 Flanges.

**AVAILABLE:** ND50 to ND2000, other ND on request

- From DN500 the motor is assisted with a gear box.

• **A = Max. width** of the valve (without actuator).

• **B = Max. height** of the valve (without actuator).

• **C = maximum** length when the gate is centred.

- The weights are approximate and vary according to the material and the valve's accessories.

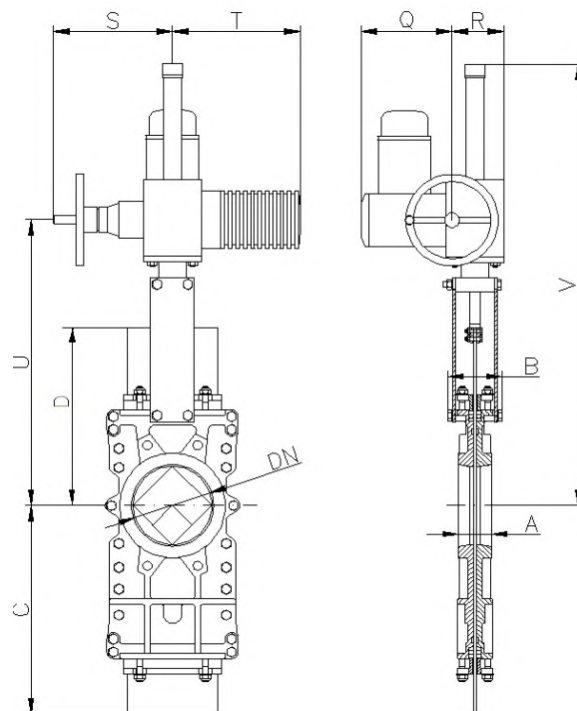

ND	$\Delta P$ (Kg/cm <sup>2</sup> )	DRAW (Nw)	TORQUE (Nm)	A	B	C	D	Q	R	S	T	U	V	Weight (kg.)
50	10	894	2.1	40	91	225	243	197	102	234	265	347	587	32
65	10	1508	3.5	40	91	265	269	197	102	234	265	374	614	33
80	10	2281	5.2	50	91	310	293	197	102	234	265	400	640	37
100	10	3561	8.2	50	91	370	334	197	102	234	265	440	680	39
125	10	5565	13	50	101	430	367	197	102	234	265	473	713	48
150	10	6419	15	60	101	495	419	197	102	234	265	525	765	58
200	8	10020	29	60	118	630	525	197	102	234	265	640	880	74
250	6	11230	32.5	70	118	770	620	197	102	234	265	741	981	108
300	6	16210	47	70	118	895	726	197	102	234	265	841	1141	132
350	5	17740	70	96	290	1050	780	197	115	256	282	944	1347	189
400	5	23260	92	100	290	1185	855	197	115	256	282	1050	1550	261
450	3	22260	89	106	290	1320	975	222	153	325	385	1147	1847	368
500	3	27470	110	110	290	1455	1064	222	153	325	385	1259	1959	497
600	3	39850	160	110	290	1720	1244	222	153	325	385	1465	2165	584
700	2	36880	212	110	320	1995	1425	222	153	325	385	1651	2451	988
800	2	48980	285	110	320	2230	1615	222	153	332	385	1865	2665	N.D.
900	2	61230	353	110	320	2465	1823	222	153	332	385	2098	2998	N.D.
1000	2	77690	457	110	320	2620	1992	222	153	332	385	2288	3178	N.D.
1100	2	95506	674	150	340	3030	2217	227	195	355	510	2575	3675	N.D.
1200	2	113710	802	150	340	3250	2351	227	195	355	510	2866	4042	N.D.
1300	2	133563	943	150	390	3430	2882	227	195	355	510	3082	4382	N.D.
1400	2	157280	1298	150	390	3680	3250	222	153	332	385	3395	4852	N.D.
1500	2	180712	1493	170	426	3930	3517	222	153	332	385	3662	5217	N.D.
1600	2	205780	1904	170	426	4272	3775	227	195	355	510	3975	5575	N.D.
1700	2	236498	2214	190	440	4615	4008	227	195	355	510	4210	5908	N.D.
1800	2	264860	2477	190	440	4886	4242	227	195	355	510	4457	6242	N.D.
1900	2	299502	3213	210	480	5158	4390	227	195	355	510	4590	6490	N.D.
2000	2	331260	3549	210	480	5430	4540	227	195	355	510	4740	6740	N.D.

N.G.: Weight not given

Table 10

## HYDRAULIC ACTUATOR (Oil pressure: 135 Kg/cm<sup>2</sup>)

The definition variables are as follow:

- **A = Max. width** of the valve (without actuator).
- **B = Max. height** of the valve (without actuator).
- **C = maximum** length when the gate is centred.

The hydraulic actuator includes:

- Cilindro Hidráulico
- Puente

**AVAILABLE:**

- From ND50 to ND2000, other ND on request.
- The weights are approximate and vary according to the material and the valve's accessories.
- Different types and brands available according to customer's requirements.

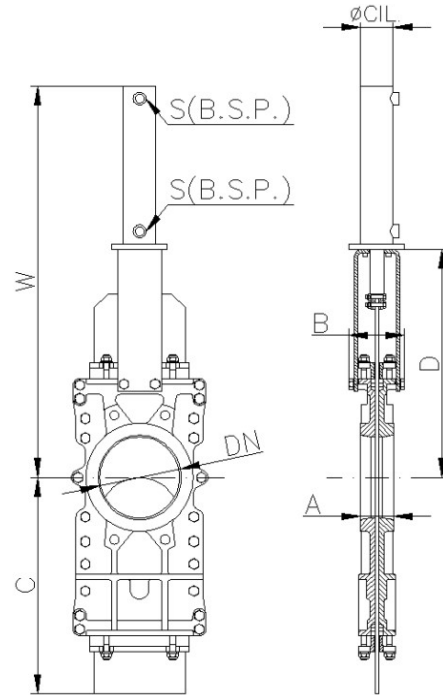

ND	ΔP (Kg/cm <sup>2</sup> )	DRAW (Nw)	A	B	C	D	W	ø CIL	ø VAST	S (B.S.P.)	OIL Cap. (dm <sup>3</sup> )	Weight (kg.)
50	10	894	40	91	225	243	459	25	18	3/8"	0.03	17
65	10	1508	40	91	265	269	500	25	18	3/8"	0.03	18
80	10	2281	50	91	310	293	559	25	18	3/8"	0.04	22
100	10	3561	50	91	370	334	620	32	22	3/8"	0.09	24
125	10	5565	50	101	430	367	683	32	22	3/8"	0.11	33
150	10	6419	60	101	495	419	755	40	28	3/8"	0.20	43
200	8	10020	60	118	630	525	927	50	28	3/8"	0.42	61
250	6	11230	70	118	770	620	1071	50	28	3/8"	0.52	99
300	6	16210	70	118	895	726	1223	50	28	3/8"	0.62	131
350	5	17740	96	290	1050	780	1360	50	28	3/8"	0.73	182
400	5	23260	100	290	1185	855	1484	63	36	3/8"	1.31	254
450	3	22260	106	290	1320	975	1693	63	36	3/8"	1.47	387
500	3	27470	110	290	1455	1064	1832	63	36	3/8"	1.62	498
600	3	39850	110	290	1720	1244	2111	80	45	3/8"	3.12	559
700	2	36880	110	320	1995	1425	2444	80	45	3/8"	3.62	983
800	2	48980	110	320	2230	1615	2734	100	56	1/2"	6.44	N.D.
900	2	61230	110	320	2465	1823	3042	100	56	1/2"	7.25	N.D.
1000	2	77690	110	320	2620	1992	3351	125	70	1/2"	10.25	N.D.
1100	2	95506	150	340	3030	2217	3560	125	70	1/2"	13.56	N.D.
1200	2	113710	150	340	3250	2351	3910	125	70	1/2"	15.05	N.D.
1300	2	133563	150	390	3430	2882	4477	160	70	1/2"	26.3	N.D.
1400	2	157280	150	390	3680	3250	4945	160	70	1/2"	28.65	N.D.
1500	2	180712	170	426	3930	3517	5354	160	70	1/2"	30.7	N.D.
1600	2	205780	170	426	4272	3775	5712	160	70	1/2"	32.7	N.D.
1700	2	236498	190	440	4615	4008	6045	200	90	1/2"	53.72	N.D.
1800	2	264860	190	440	4886	4242	6379	200	90	1/2"	57.35	N.D.
1900	2	299502	210	480	5158	4390	6668	200	90	1/2"	60.16	N.D.
2000	2	331260	210	480	5430	4540	6918	200	90	1/2"	63.65	N.D.

N.G.: Weight not given

Table 11



## INFORMATION ON FLANGE DIMENSIONS

ND	ΔP (Kg/cm2)	•	o	Metric	Prof.	ØK
50	10	4	-	M 16	8	125
65	10	4	-	M 16	8	145
80	10	4	4	M 16	9	160
100	10	4	4	M 16	9	180
125	10	4	4	M 16	9	210
150	10	4	4	M 20	10	240
200	8	4	4	M 20	10	295
250	6	8	4	M 20	12	350
300	6	8	4	M 20	12	400
350	5	12	4	M 20	21	460
400	5	12	4	M 24	21	515
450	3	16	4	M 24	22	565
500	3	16	4	M 24	22	620
600	3	16	4	M 27	22	725
700	2	20	4	M 27	22	840
800	2	20	4	M 30	22	950
900	2	24	4	M 30	20	1050
1000	2	24	4	M 33	20	1160
1100	2	28	4	M 33	20	1270
1200	2	28	4	M 36	22	1380
1300	2	28	4	M 36	26	1490
1400	2	32	4	M 39	26	1590
1500	2	32	4	M 39	35	1700
1600	2	36	4	M 45	40	1820
1700	2	40	4	M 45	40	1920
1800	2	40	4	M 45	40	2020
1900	2	44	4	M 45	45	2120
2000	2	44	4	M 45	45	2230

Tabla 12

### ANSI B16, CLASE 150

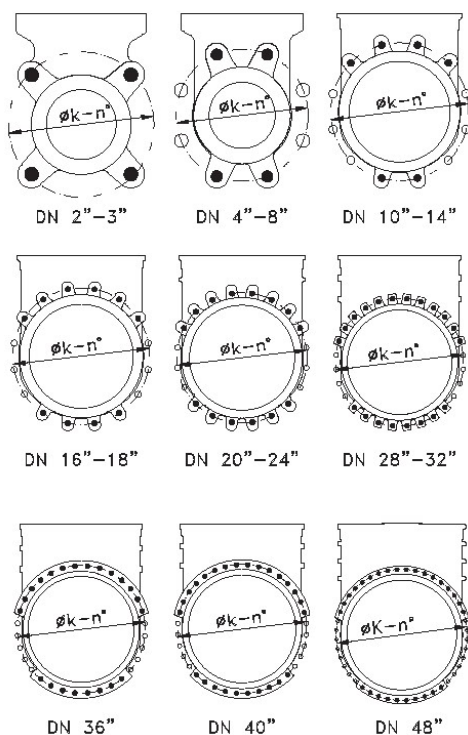

### EN 1092-2 PN10

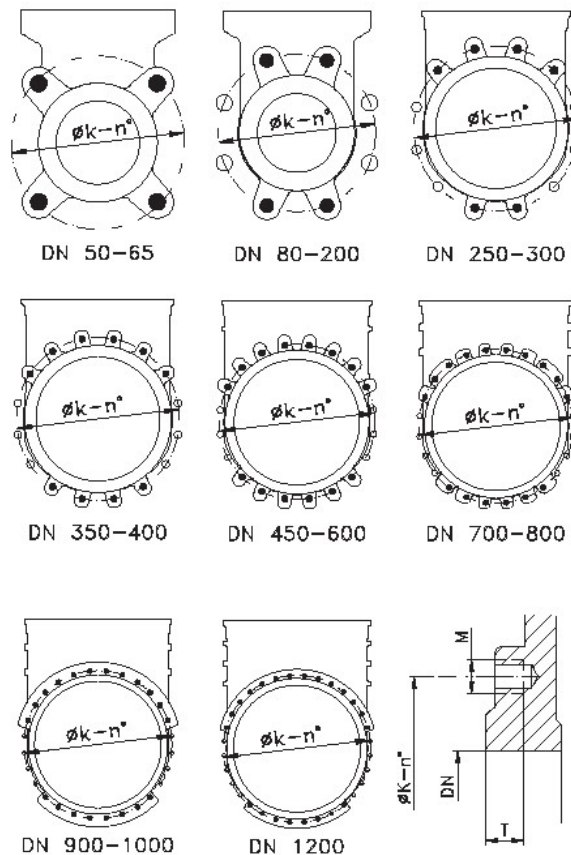

- BLIND TAPED HOLES
- THROUGH HOLE

ND	•	o	R UNC	PROF.	ØK
2"	4	-	5/8"	8	120,6
2 1/2"	4	-	5/8"	8	139,7
3"	4	-	5/8"	9	152,4
4"	4	4	5/8"	9	190,5
5"	4	4	3/4"	9	215,9
6"	4	4	3/4"	10	241,3
8"	4	4	3/4"	10	298,4
10"	8	4	7/8"	12	361,9
12"	8	4	7/8"	12	431,8
14"	8	4	1"	21	476,2
16"	12	4	1"	21	539,7
18"	12	4	1 1/8"	22	577,8
20"	16	4	1 1/8"	22	635
24"	16	4	1 1/4"	22	749,3
28"	24	4	1 1/4"	22	863,6
30"	24	4	1 1/4"	22	914,4
32"	24	4	1 1/2"	22	977,9
36"	28	4	1 1/2"	20	1085,9
40"	32	4	1 1/2"	20	1200,2

Table 13