



DSS VALVES

Designed for
Severe Service

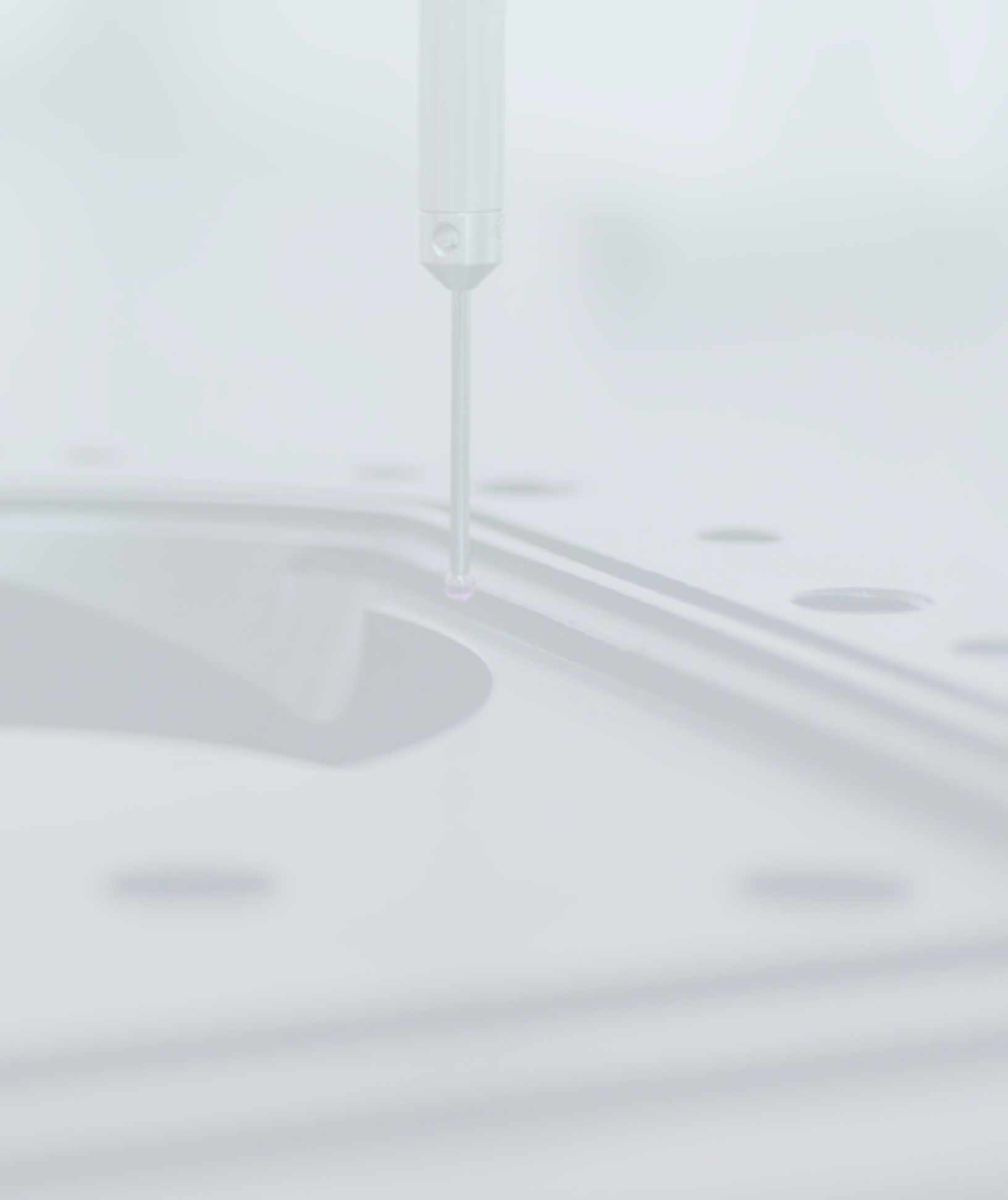

TABLE OF CONTENTS

1	Introduction	5
2	The Evolution of the Severe Service Knife Gate Valve	6
3	Designed for Severe Service	8
3.1	Key Industries.....	8
4	Standard Features	9
5	Severe Service Knife Gate Valve	10
5.1	Features and Benefits	11
5.2	Parts Diagram and List—Handwheel.....	12
5.3	Parts Diagram and List—Pneumatic Cylinder	14
5.4	Dimensions.....	16
6	DBB Double Block and Bleed	18
6.1	Features and Benefits	19
6.2	Parts Diagram and List.....	20
6.3	Dimensions.....	22
7	Design Specs, Material List and Torque Values	23
8	Ordering Information	24
9	Contact Information	28



Introducing DSS Valves

DSS Valves is a streamlined team of engineering and manufacturing professionals dedicated to creating premier Severe Service Knife Gate Valves (SSKGVs) for critical services in your industry.

We specialize in creating valves that thrive in the harshest environments and our products are known for their ability to handle differential pressure scenarios, corrosive materials, extreme temperatures and detrimental solids. We provide prompt delivery, honest customer service and a technologically advanced product made in North America, delivered throughout the world.

Too often have we seen corporate acquisitions of independent valve companies cause a decrease in product quality and eliminate the relationship between customer and manufacturer. We believe that by mastering the design, build and supply of the Severe Service Knife Gate Valve while listening to our customer's needs, we can provide a superior product perfectly crafted for the task at hand.

North American Made, Internationally Sold

Our valves are designed and manufactured entirely on North American soil. From engineering and milling, to welding, assembly and testing, each critical step takes place in the United States and Canada.

DSS Valves International is the international sales division of the DSS Valves brand. Founded by experienced valve professionals with extensive application expertise, our primary goal is to supply premier Knife Gate Valve solutions and other Severe Service applications to customers operating steel, mining, pulp & paper, water/wastewater and oil and gas plants around the world.



With a background in distribution, we enable DSS Valves to focus on the manufacturing process and utilize our established distribution network and go-to-market experience to sell valves based on your applications' needs.

THE EVOLUTION of the Severe Service Knife Gate Valve

The Knife Gate Valve began its journey in the Swedish Pulp and Paper industry. The market demanded an inexpensive valve for pulp stock applications, and a revolutionary valve design for the era was born. Known as the Knife Gate Valve, this new technology was capable of low pressure uni-directional general purpose isolation.

The simplistic and inexpensive design did have its problems. The hypothesis that the pulp stock in the water slurry would dewater around the closed gate and seat, thus forming a tighter seal resulted in extremely high allowable leakage rates and fugitive emissions (leakage both inside and outside the piping system). Unfortunately, the original design often acted more as a sieve than a valve.

The 1950's saw a new patent for the Knife Gate Valve in the U.S. From here, a variety of designs began to improve the functionality and capabilities of the valve.



In 2017, DSS Valves officially entered the market, boasting the most technologically advanced Severe Service Knife Gate Valve. The design completely removes the chance for fugitive emissions, surpasses the rigorous standards for Severe Service defined by the MSS, and provides bi-directional Zero Leakage to ASME Class 600 (100 Barg).

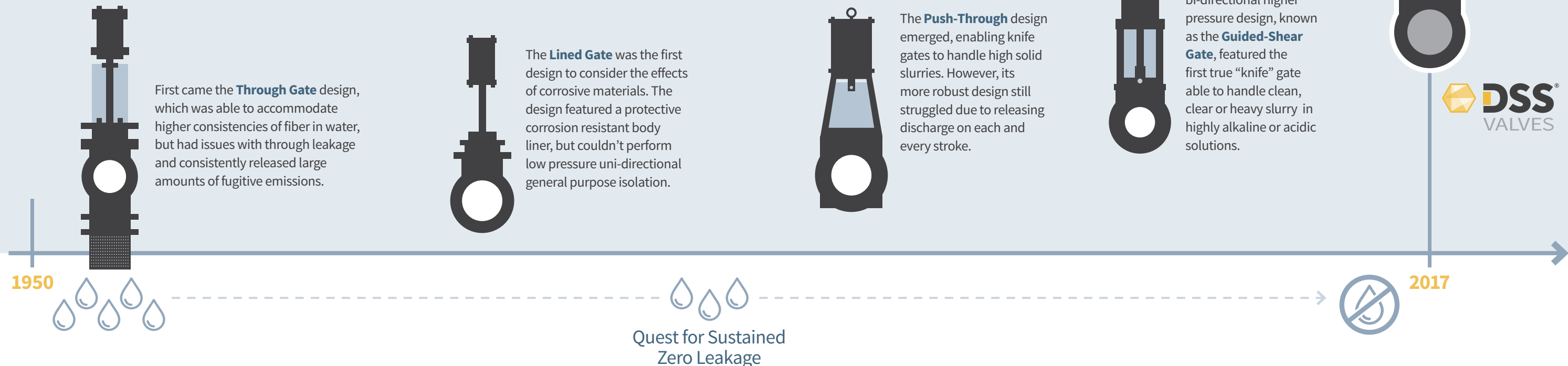

Designed for Severe Service

As industrial processes continue to increase in complexity and risk, valve design and performance is crucial to maintaining consistent plant operation and maintaining your bottom line. Valves are critical to protecting your workers and the environment; they need to be reliable in the harshest of conditions.



READY FOR ANY APPLICATION

DSS Valves is known for creating dependable Severe Service Valves that outlast the competition in any scenario. Just because they're built to thrive in the most severe conditions, doesn't mean they shouldn't be considered for more general applications. Investing in a premium product pays dividends through increased service life and reduced downtime, making the overall cost of ownership much less in the long run.

Key Industries

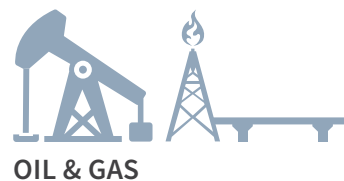
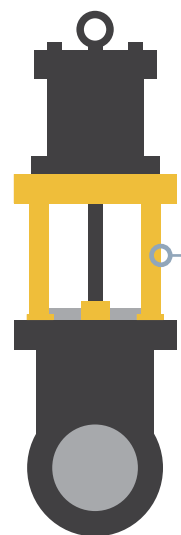

Premium Components Come Standard

For starters, all valves meet or exceed MSS SP-135, and include the following key features:

- Wider gates, internal guides, and full bore matching standard pipe sizes
- Energized resilient perimeters with hybrid resilient/metallic seats
- Fully indexable Ni-hard wear rings
- Wider and thicker primary and secondary transverse seals that provide better sealing at higher pressures.
- Dual transverse seals and secondary body seals for 4" bore sizes and larger
- Thicker primary body seal (10mm for ≥8" bore sizes, 6mm for ≤6" bore sizes)
- Stainless steel screws for dust covers
- Four bolt yokes for valves with 6" bore size and larger
- Fully supported flanges eliminates the need for pipe nipples on DBB valves
- SAE 660 bronze ACME nuts for smoother operation
- Larger ACME screws for ≥26" bore sizes
- 17-4ph cylinder clevis pins that are stronger and corrosion resistant



SSKGV

Severe Service Knife Gate Valve



Severe Service Knife Gate Valve

Features and Benefits

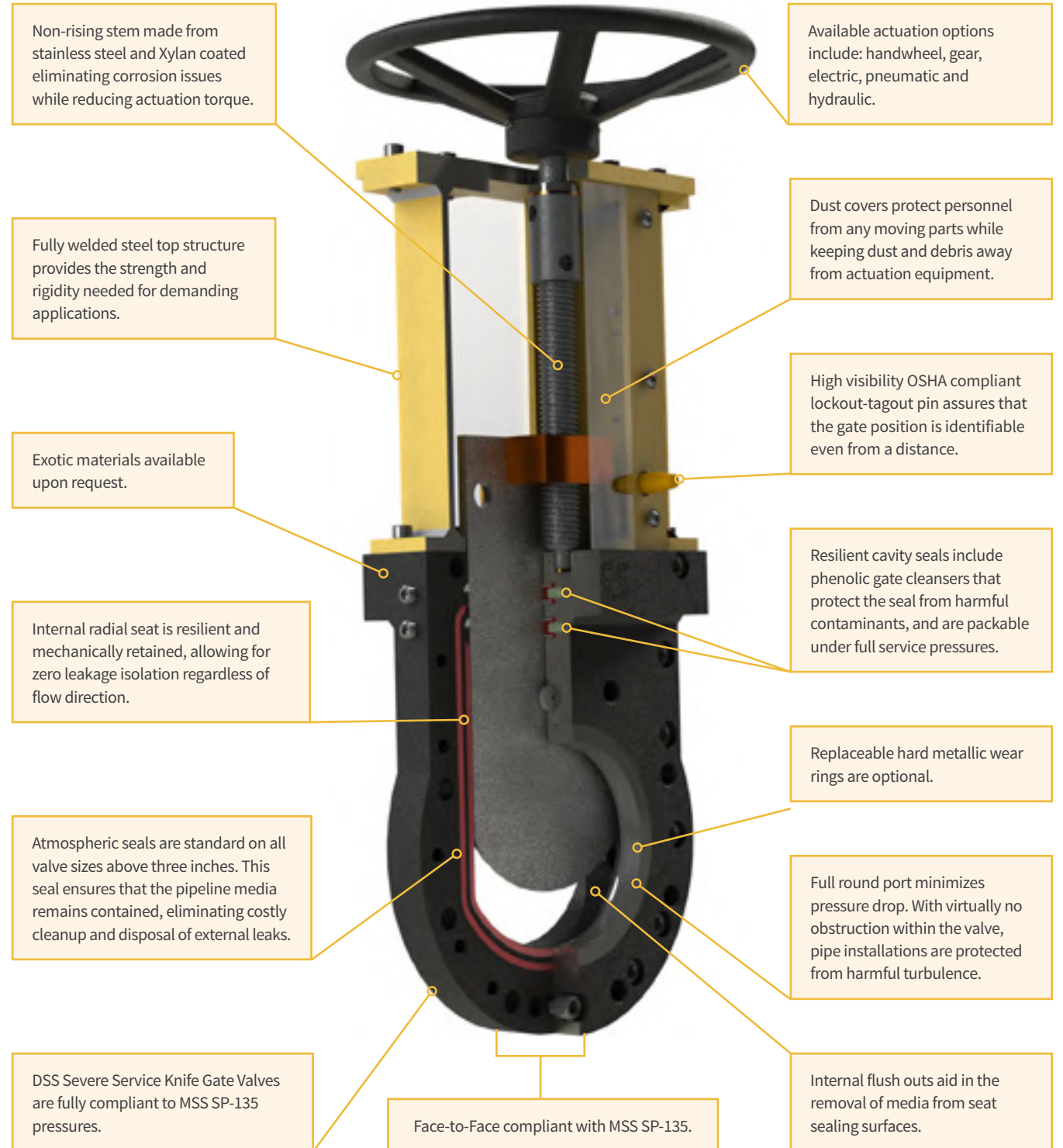

Severe Service Knife Gate Valve

Parts Diagram and List SSKGV ASME Class 150, 300 and 600—Handwheel

Parts in this diagram and list represent a 6" ASME Class 150. Parts may vary slightly depending on order placed.

ITEM #	PART NUMBER	QTY	DESCRIPTION
1*	000-191-00-093	6	Disc, Gate Glide
2*	000-195-00	4	Packing
3*	40-006-024-093	1	Seal, Primary
4*	40-006-028-093	1	Seal, Secondary
5	50-037-16-0100-089	16	SHCS, 3/8-16 X 1.00
6	50-050-13-0100-089	13	SHCS, 1/2-13 X 1.00
7	50-050-13-0225-089	2	SHCS, 1/2-13 X 2.25
8	52-025-20-0050-088	12	FBHSCS, 1/4-20 X .500
9	55-050-13-0125-088	8	SSS, 1/2-13 X 1.250
10	65-125-251-312-2	2	Pop-Rivet, Domed Head, 1/8" Dia. X .251"-.312" Range
11	65-187-251-375-2	1	Pop-Rivet, Domed Head, 3/16" Dia. X .251"-.375" Range
12	68-062-0524	1	Pin, Lockout-Tagout
13	69-063-18-2	1	Lanyard, 18 inch
14	57-025-20-0300-089	1	HSS, 1/4-20 X 3.000
15	99-150-300-2	1	Tag, Identification
16	106-015-00-009	1	Body, Front

ITEM #	PART NUMBER	QTY	DESCRIPTION
17	106-035-00-009	1	Body, Back
18	106-050-00-050	1	Gate
19*	106-172-00-093	4	Seal, Cavity
20*	106-181-00-093	4	Seal, Quarter
21*	106-186-00-090	6	Blade, Seal Scraper
22*	106-187-00-090	1	Blade, Secondary Seal Scraper
23*	106-189-00-090	1	Blade, Primary Seal Scraper
24	106-220-00-076	1	Yoke, Left
25	106-230-00-076	1	Yoke, Right
26	106-240-00-075	2	Cover, Dust
27	106-260-00-062	1	Nut, Screw
28	106-270-00-054	1	Screw, Assembly
29	106-274-00-069	1	Disc, Thrust
30	106-277-00-054	1	Washer, Thrust
31	106-280-00-069	1	Bearing, Thrust
32	106-312-00-011	1	12" Handwheel
33	106-405-00-076	1	Plate, Screw

*Recommended spare parts. Available in standard repair kit.

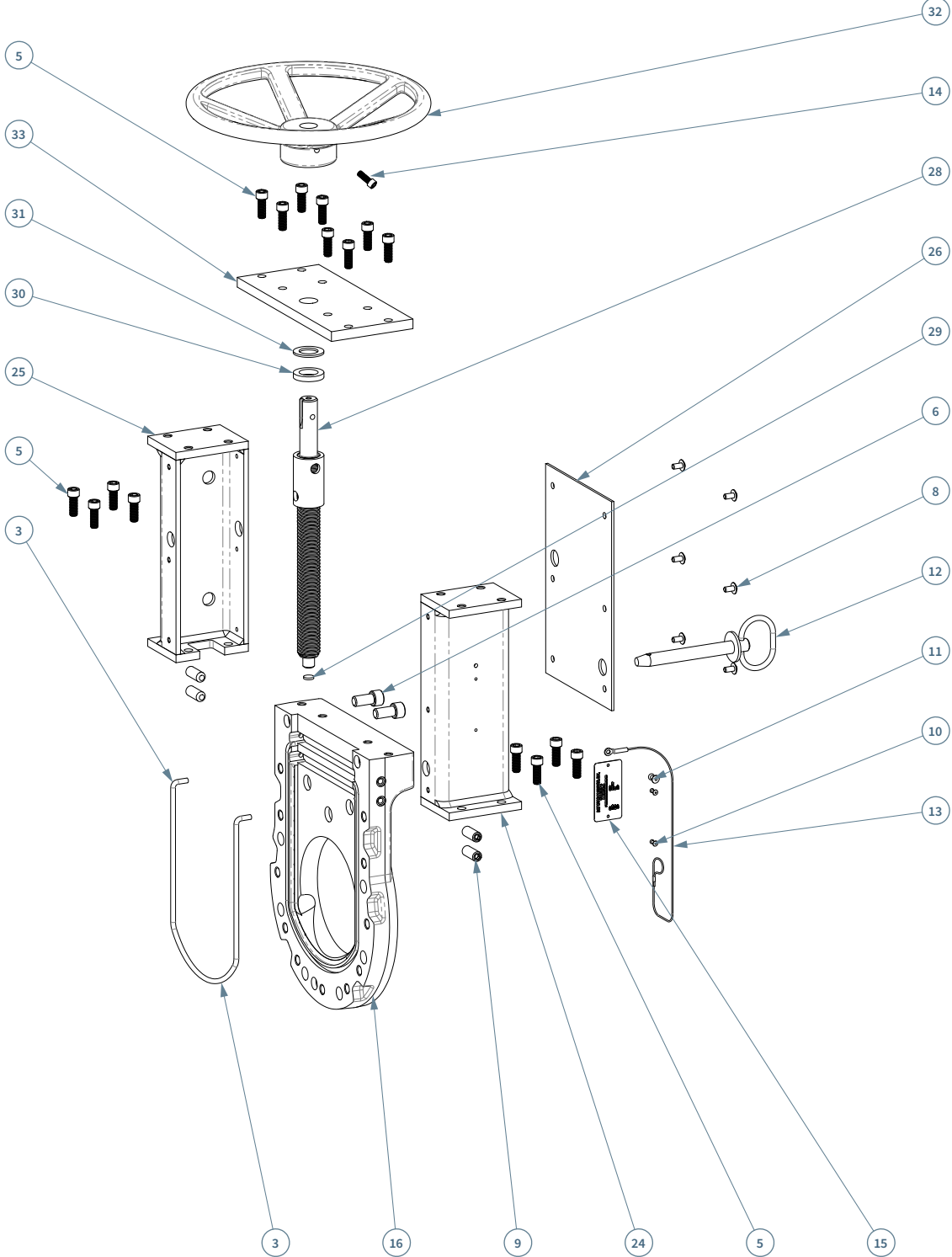
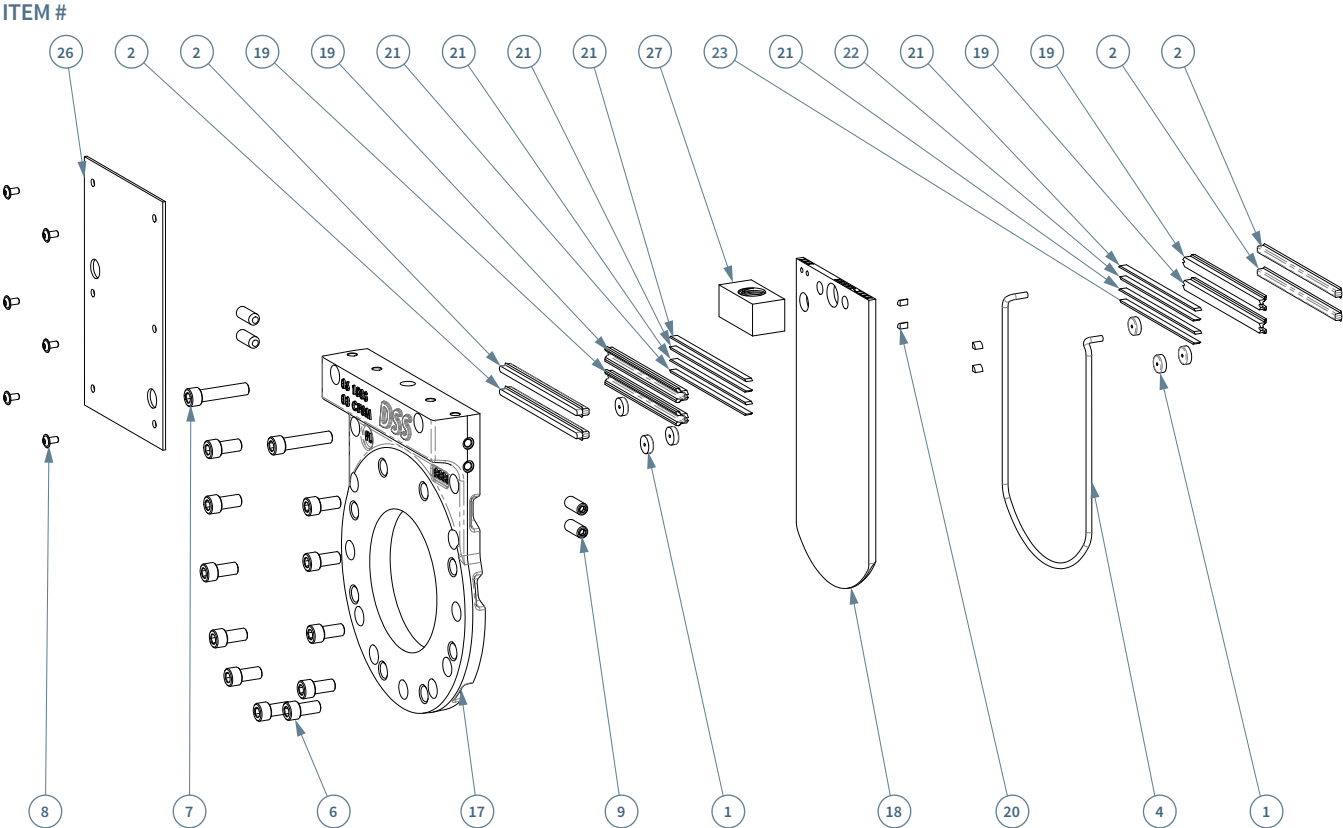

Severe Service Knife Gate Valve

Parts Diagram and List

SSKGV ASME Class 150, 300 and 600—Pneumatic Cylinder

Parts in this diagram and list represent a 6" ASME Class 150. Parts may vary slightly depending on order placed.

ITEM #	PART NUMBER	QTY	DESCRIPTION
1*	000-191-00-093	6	Disc, Gate Glide
2*	000-195-00	4	Packing
3*	40-006-024-091	1	Seal, Primary
4*	40-006-028-091	1	Seal, Secondary
5	50-037-16-0100-089	8	SHCS, 3/8-16 X 1.00
6	50-050-13-0100-089	11	SHCS, 1/2-13 X 1.00
7	50-050-13-0150-089	4	SHCS, 1/2-13 X 1.500
8	50-050-13-0225-089	2	SHCS, 1/2-13 X 2.25
9	51-038-16-0100-089	8	FHSCS, 3/8"-16 X 1.00
10	52-025-20-0050-088	12	FBHSCS, 1/4-20 X .500
11	55-050-13-0125-088	8	SSS, 1/2-13 X 1.250
12	65-125-251-312-2	2	Pop-Rivet, Domed Head, 1/8" Dia. X .251"-.312" Range
13	65-187-251-375-2	1	Pop-Rivet, Domed Head, 3/16" Dia. X .251"-.375" Range
14	67-100-0163-2	1	Pin, Lockout-Tagout
15	68-062-0524	1	Pin, Locating
16	69-063-18-2	1	Lanyard, 18 inch

ITEM #	PART NUMBER	QTY	DESCRIPTION
17	71-075-16-1	1	Nut, Hex Jam
18	90-100-2	2	Retaining Ring
19	99-150-300-2	1	Tag, Identification
20	106-06-21-11	1	6 inch PC with 6 inch stroke
21	106-015-00-009	1	Body, Front
22	106-035-00-009	1	Body, Back
23	106-050-00-050	1	Gate
24*	106-172-00-091	4	Seal, Cavity
25*	106-181-00-093	4	Seal, Quarter
26*	106-186-00-090	6	Blade, Seal Scraper
27*	106-187-00-090	1	Blade, Secondary Seal Scraper
28*	106-189-00-090	1	Blade, Primary Seal Scraper
29	106-220-00-076	1	Yoke, Left
30	106-230-00-076	1	Yoke, Right
31	106-240-00-075	2	Cover, Dust
32	106-290-00-081	1	Clevis, Cylinder
33	106-625-00-076	1	Plate, Screw

*Recommended spare parts. Available in standard repair kit.

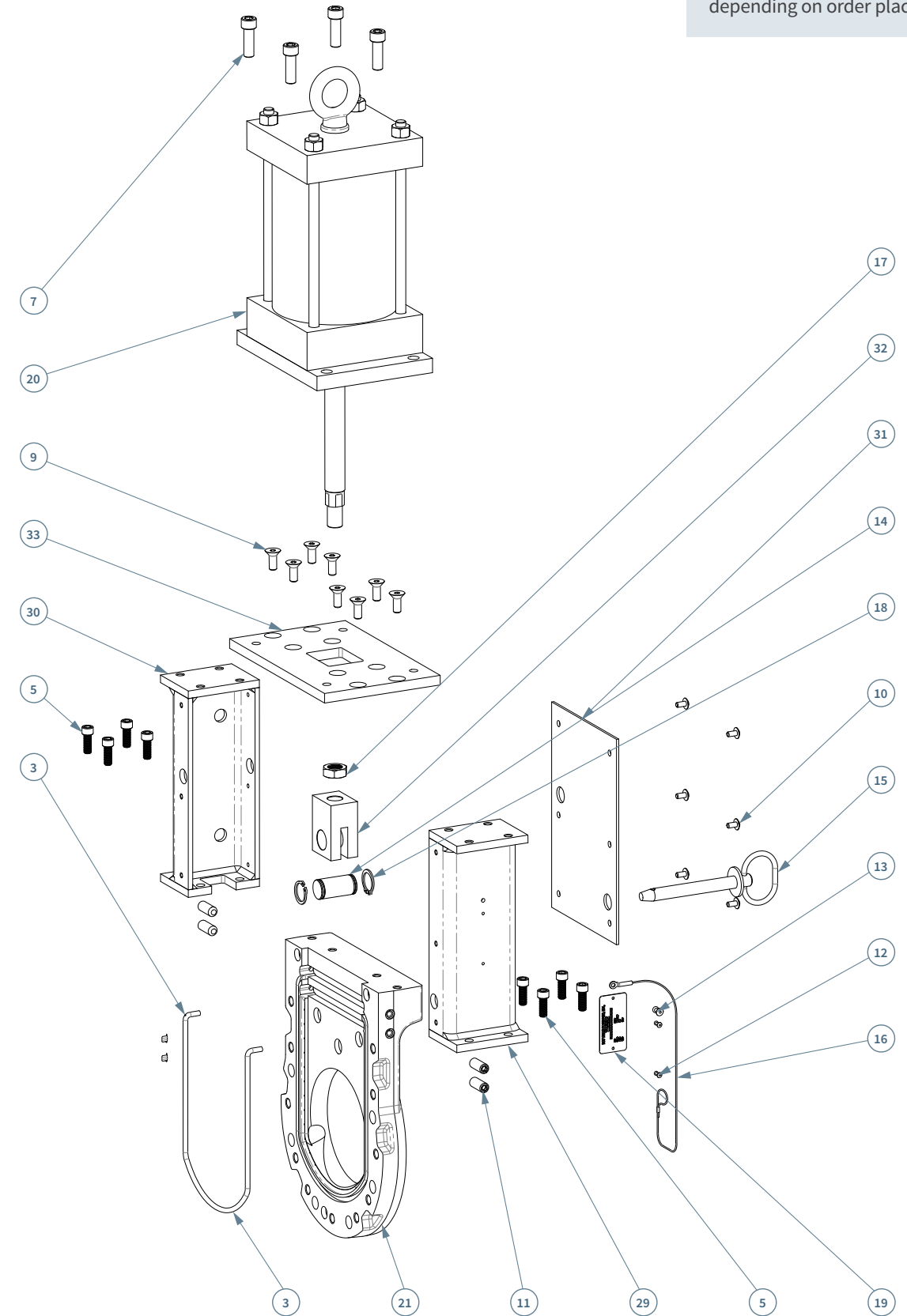
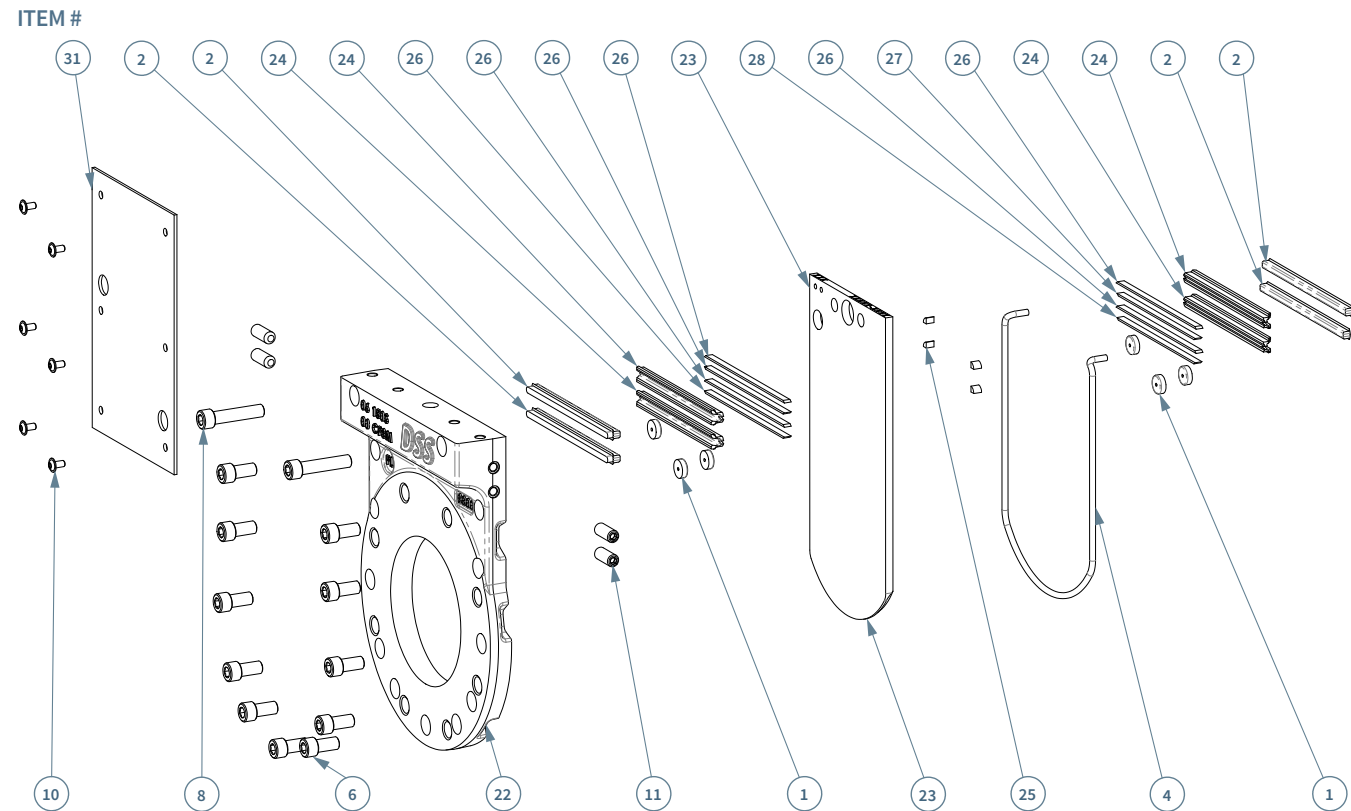

Severe Service Knife Gate Valve

Dimensions

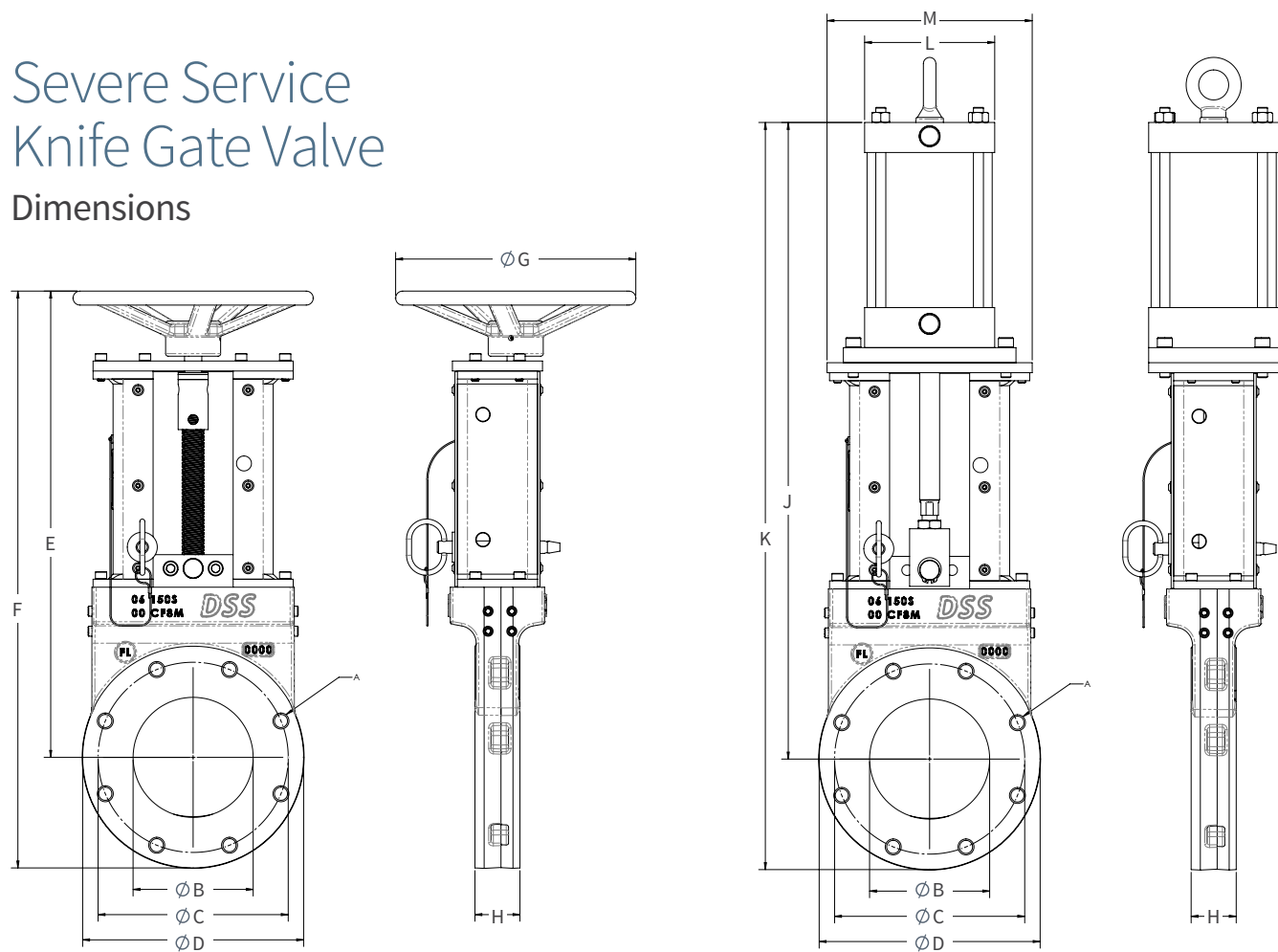

SSKGV CLASS 300 DIMENSIONS

Valve Size		Flange									Dimensions						Standard Pneumatic Cylinder Bore	Valve Weight				
NPS	DN [mm]	Class	QTY.	ØA (THREAD)	ØA (CLEARANCE)	ØB	ØC	ØD	E	F	ØG	H	H	J	K	L		M	Hand-wheel	Bevel Gear	PC1 (Std.)	HC1 (Std.)
2	50	300	8	5/8-11	0.75	1.88	5.00	6.50	14.70	17.95	10.00	2.75	2.75	17.58	20.83	4.50	6.25	4.00	40	46	64	53
3	75		8	3/4-10	0.88	2.88	6.62	8.25	16.70	20.84	10.00	2.75	4.00	20.01	24.14	4.50	6.25	4.00	71	79	96	84
4	100		8	3/4-10	0.88	3.83	7.88	10.00	19.26	24.26	10.00	2.75	4.12	22.85	27.85	6.50	8.63	6.00	95	105	152	134
6	150		12	3/4-10	0.88	5.76	10.62	12.50	23.71	29.96	12.00	3.15	4.12	30.05	36.30	8.50	10.00	8.00	177	189	236	220
8	200		12	7/8-9	1.00	7.63	13.00	15.00	29.42	36.92	12.00	3.50	4.63	38.47	45.97	10.63	12.75	10.00	266	278	431	312
10	250		16	1-8	1.12	9.75	15.25	17.50	33.59	42.34	16.00	4.68	5.38	44.08	52.83	12.75	14.50	12.00	360	384	700	433
12	300		16	1 1/8-8	1.25	11.75	17.75	20.50	36.81	47.06	20.00	5.00	5.63	50.64	60.89	14.75	16.50	14.00	-	621	1115	738
14	350		20	1 1/8-8	1.25	13.00	20.25	23.00	41.30	52.80	20.00	5.50	6.25	56.05	67.55	17.00	19.00	16.00	-	860	1592	982
16	400		20	1 1/4-8	1.38	15.00	22.50	23.50	-	-	-	5.50	6.63	62.33	74.08	17.00	21.75	16.00	-	1174	2135	1392
18	450		24	1 1/4-8	1.38	17.00	24.75	28.00	-	-	-	6.25	7.00	68.33	82.33	17.00	24.00	16.00	-	1453	2666	1671
20	500		24	1 1/4-8	1.38	19.00	27.00	30.50	-	-	-	7.44	7.44	75.20	90.45	21.00	27.00	20.00	-	2062	3286	2380
22	550		24	1 1/2-8	1.63	21.00	29.25	33.00	-	-	-	8.50	8.50	81.70	98.20	23.00	28.50	22.00	-	2658	3894	3112
24	600		24	1 1/2-8	1.63	23.00	32.00	36.00	-	-	-	8.50	8.50	87.70	105.70	23.00	30.50	22.00	-	3121	4368	3559
26	650		28	1 5/8-8	1.75	25.00	34.50	38.25	-	-	-	8.50	8.50	97.38	116.51	25.00	32.25	24.00	-	3424	-	-
28	700		28	1 5/8-8	1.75	27.00	37.00	40.75	-	-	-	10.00	10.00	102.14	122.52	27.50	34.50	26.00	-	4150	-	-
30	750		28	1 3/4-8	1.88	29.00	39.25	43.00	-	-	-	10.50	10.50	106.88	128.38	27.50	36.50	26.00	-	4770	-	-
32	800		28	1 7/8-8	2.00	31.00	41.50	45.25	-	-	-	11.50	11.50	115.00	137.63	29.72	39.00	28.00	-	5810	-	-
36	900		32	2-8	2.12	35.00	46.00	50.00	-	-	-	12.00	12.00	126.57	151.57	33.63	43.00	32.00	-	7220	-	-

SSKGV CLASS 150 DIMENSIONS

Valve Size		Flange									Dimensions						Standard Pneumatic Cylinder Bore	Valve Weight				
NPS	DN [mm]	Class	QTY.	ØA (THREAD)	ØA (CLEARANCE)	ØB	ØC	ØD	E	F	ØG	H	H	J	K	L		M	Hand-wheel	Bevel Gear	PC1 (Std.)	HC1 (Std.)
2	50	150	4	5/8-11	0.75	1.88	4.75	6.00	14.60	17.60	10.00	2.00	2.75	18.57	21.57	3.75	5.50	3.25	36	42	43	49
3	75		4	5/8-11	0.75	2.88	6.00	7.50	16.60	20.35	10.00	2.00	4.00	21.76	25.51	3.75	5.50	3.25	57	65	65	71
4	100		8	5/8-11	0.75	4.00	7.50	9.00	18.58	23.08	10.00	2.00	4.12	24.63	29.13	4.50	6.25	4.00	71	81	83	86
5	125		8	3/4-10	0.88	5.00	8.50	10.00	21.41	26.41	12.00	2.00	-	26.54	31.54	5.50	10.00	5.00	100	124	127	141
6	150		8	3/4-10	0.88	6.00	9.50	11.00	23.29	28.79	12.00	2.25	2.50	31.80	37.30	6.50	10.25	6.00	115	127	143	157
8	200		8	3/4-10	0.88	8.00	11.75	13.50	29.33	36.08	12.00	2.75	2.88	37.16	43.91	8.50	12.75	8.00	209	221	269	254
10	250		12	7/8-9	1.00	10.00	14.25	16.00	33.19	41.19	12.00	2.75	3.12	43.58	51.58	10.63	14.50	10.00	262	274	429	310
12	300		12	7/8-9	1.00	12.00	17.00	19.00	32.64	42.14	16.00	3.00	3.25	50.08	61.95	12.75	16.75	12.00	397	409	627	469
14	350		12	1-8	1.12	13.25	18.75	21.00	40.80	51.33	16.00	3.00	3.62	55.56	66.09	14.75	19.00	14.00	-	527	856	591
16	400		16	1-8	1.12	15.25	21.25	23.50	-	-	-	3.50	3.75	61.83	73.62	14.75	21.75	14.00	-	809	1311	959
18	450		16	1 1/8-8	1.25	17.25	22.75	25.00	-	-	-	3.50	4.12	67.83	80.38	14.75	24.00	14.00	-	940	1448	1098
20	500		20	1 1/8-8	1.25	19.25	25.00	27.50	-	-	-	4.50	4.50	74.58	88.33	19.00	26.25	18.00	-	1366	1969	1532
22	550		20	1 1/4-8	1.38	21.25	27.25	29.50	-	-	-	4.50	-	80.58	95.33	23.00	28.50	20.00	-	1552	2320	1552
24	600		20	1 1/4-8	1.38	23.25	29.50	32.00	-	-	-	4.50	5.00	86.33	102.33	23.00	30.25	20.00	-	1708	2475	1967
26	650		24	1 1/4-8	1.38	25.25	31.75	34.50	-	-	-	6.75	7.09	93.44	110.69	23.00	32.25	22.00	-	2378	-	-
28	700		28	1 1/4-8	1.38	27.25	34.00	36.50	-	-	-	7.12	7.12	100.45	118.70	25.25	34.25	24.00	-	2860	-	-
30	750		28	1 1/4-8	1.38	29.25	36.00	38.75	-	-	-	7.38	8.25	103.58	122.96	25.25	36.25	24.00	-	3433	-	-
32	800		28	1 1/2-8	1.63	31.25	38.5	41.75	-	-	-	8.12	8.62	112.51	133.39	27.50	39.00	26.00	-	4090	-	-
36	900		32	1 1/2-8	1.63	35.25	42.75	46.00	-	-	-	8.88	9.84	125.70	148.70	31.00	43.00	30.00	-	5320	-	-

SSKGV CLASS 600 DIMENSIONS

Valve Size		Flange						Face-to-Face
NPS	DN [mm]	Class	QTY.	ØA (THREAD)	ØA (CLEARANCE)	ØC	ØD	
2	50	600	8	5/8-11	0.75	5.00	6.50	3.25
3	75		8	3/4-10	0.88	6.62	8.25	3.50
4	100		8	7/8-9	1.00	8.50	10.75	4.00
6	150		12	1-8	1.13	11.50	14.00	5.00
8	200		12	1 1/8-8	1.25	13.75	16.50	6.00
10	250		16	1 1/4-8	1.38	17.00	20.00	6.75
12	300		20	1 1/4-8	1.38	19.25	22.00	7.50
14	350		20	1 3/8-8	1.50	20.75	23.75	8.00
16	400		20	1 1/2-8	1.63	23.75	27.00	8.50
18	450		20	1 5/8-8	1.75	25.75	29.25	9.25
20	500		24	1 5/8-8	1.75	28.50	32.00	10.25
24	600		24	1 7/8-8	2.00	33.00	37.00	12.00
26	650		28	1 7/8-8	2.00	36.00	40.00	13.00
28	700		28	2-8	2.13	38.00	42.25	14.00
30	750		28	2-8	2.13	40.25	44.50	15.00
32	800		28	2 1/4-8	2.38	42.50	47.00	15.25
36	900		28	2 1/2-8	2.63	47.00	51.75	17.50

*Please consult DSS Valves or an authorized distributor for bore sizing, actuator sizing or specialty orders. Larger sizes and higher pressure classes are available upon request.

DBB

Double Block and Bleed

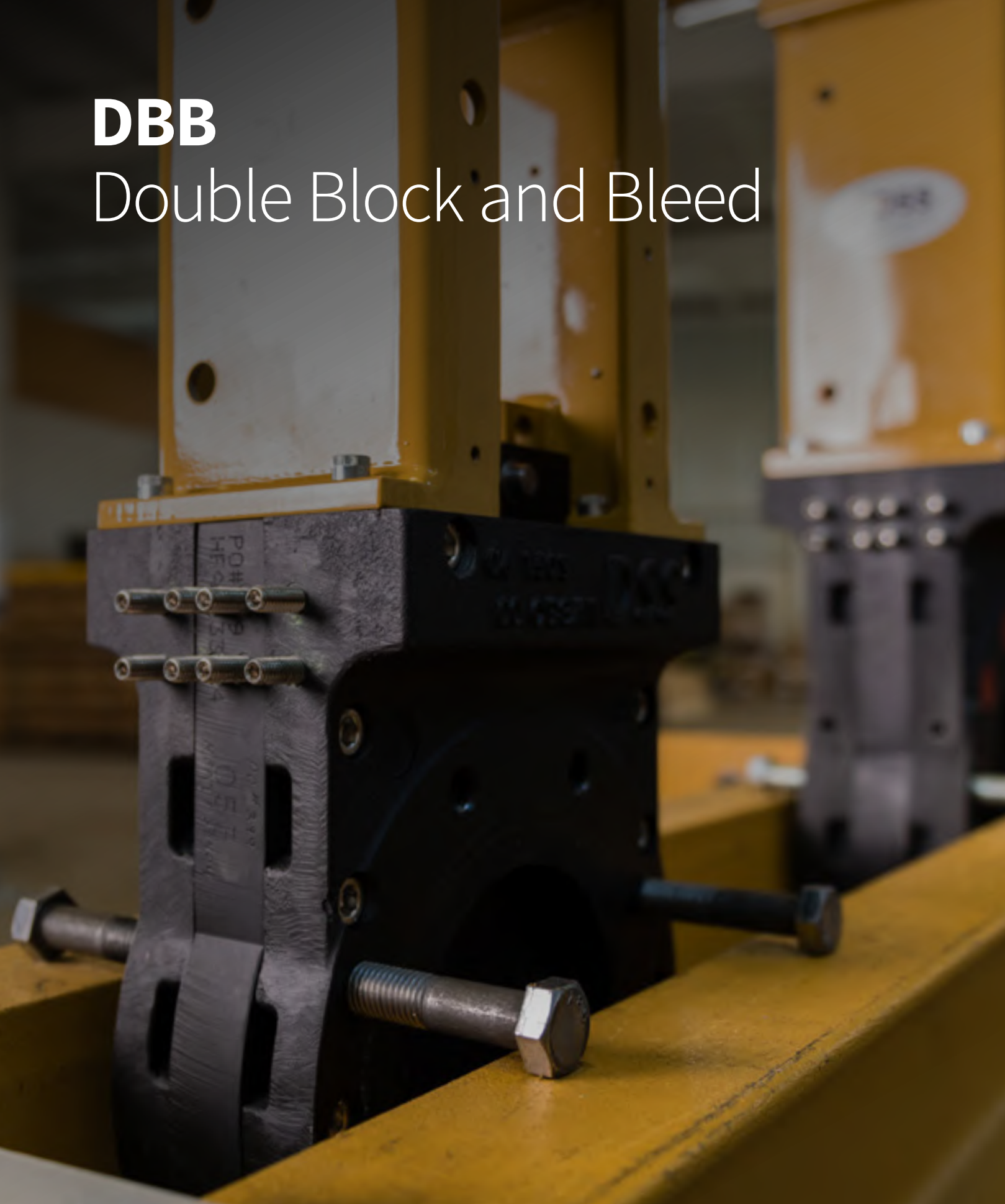

Double Block and Bleed Features and Benefits

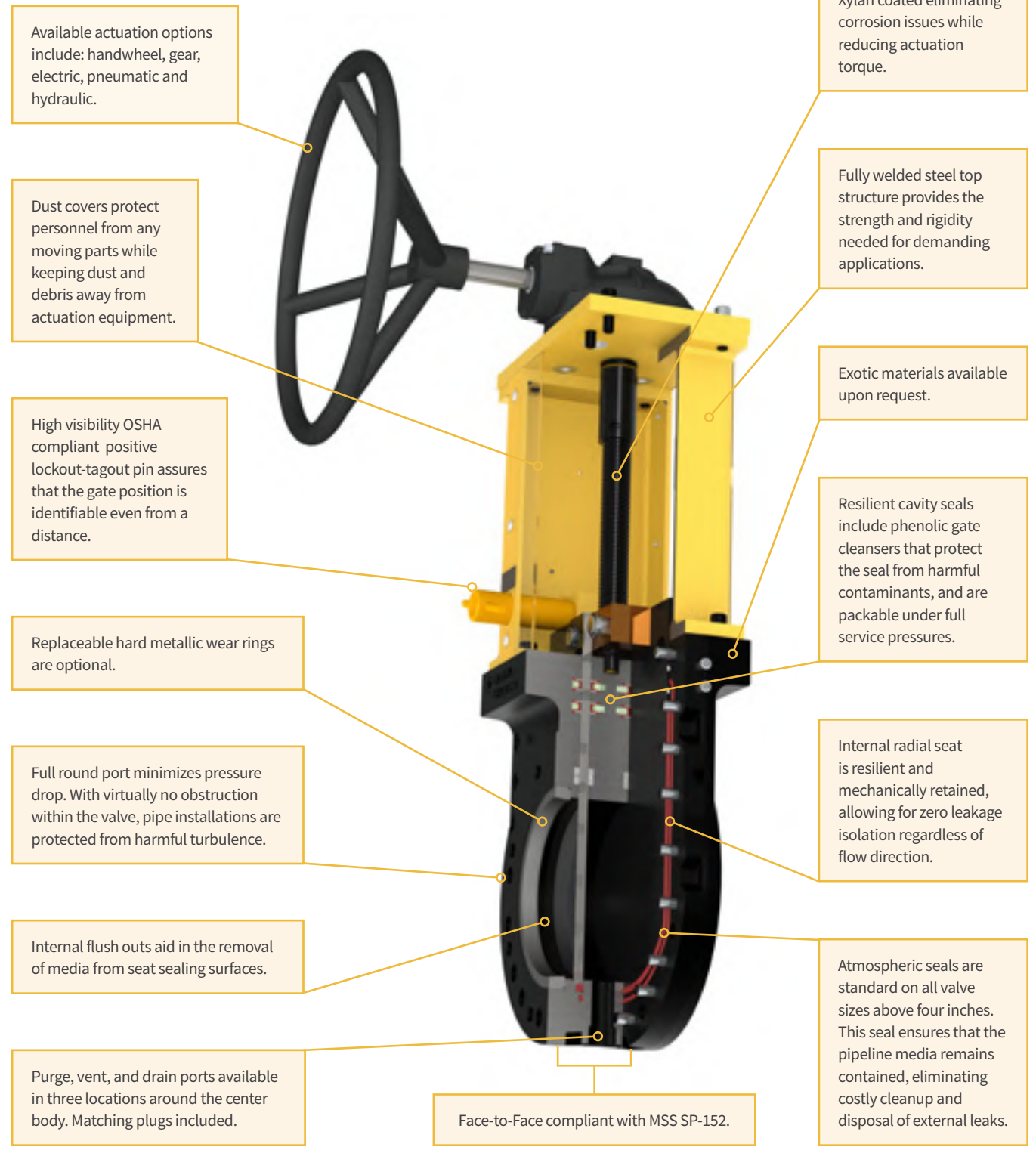

Double Block and Bleed

Parts Diagram and List

Parts in this diagram and list represent an 8" Class 150 DBB. Parts may vary slightly depending on order placed.

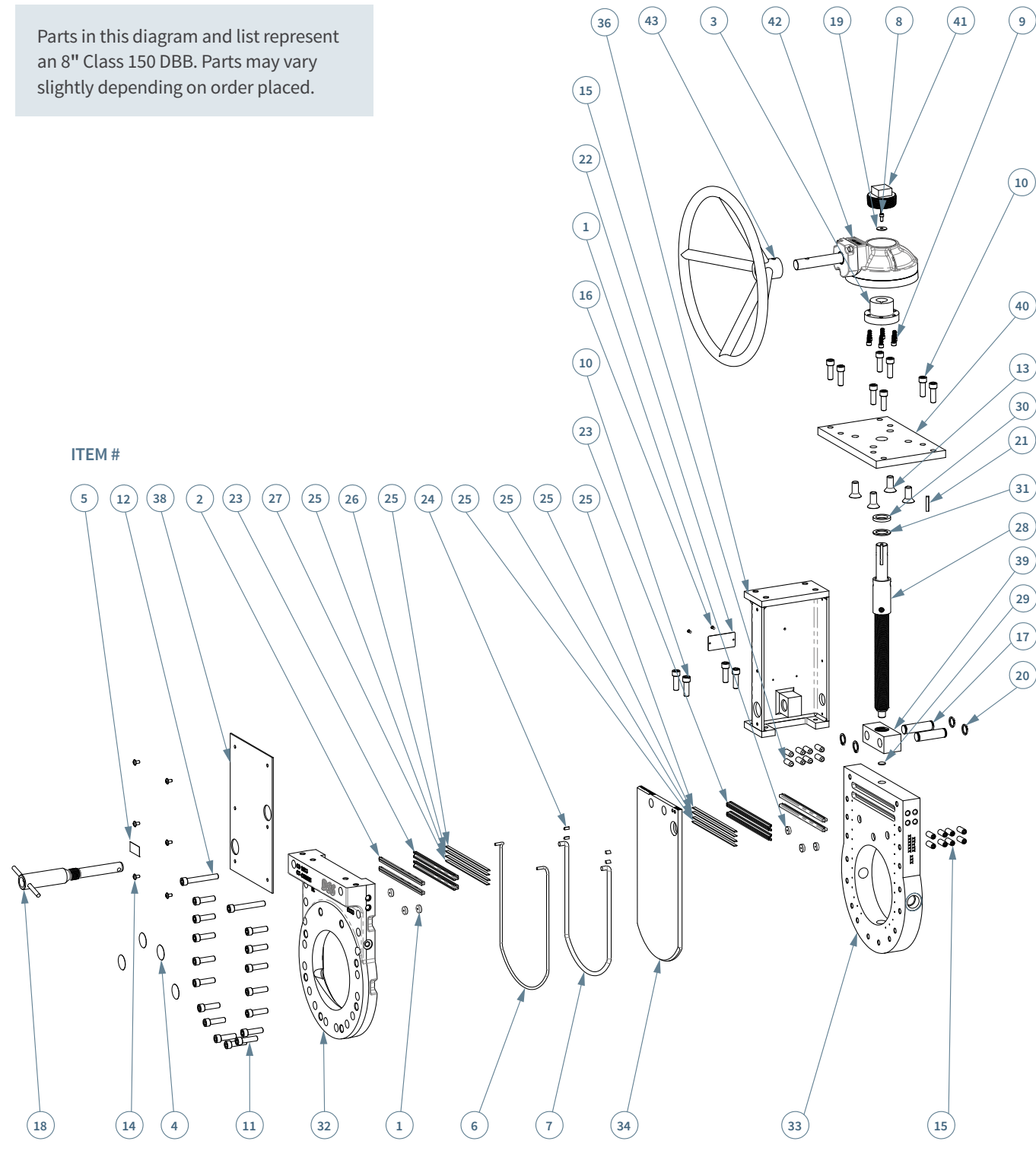

ITEM #	PART NUMBER	QTY	DESCRIPTION
1*	000-191-00-093	12	Disc, Gate Glide
2*	000-195-00	2	Packing
3	01-410-113-081	1	Drive Hub, Bevel Gear 3
4	20-150-3-1	8	Decal, Blind Hole Warning
5	21-102-3-1	1	Decal, Locator Pin Warning
6*	40-006-036-095	2	Seal, Secondary
7*	40-010-032-097	2	Seal, Primary
8	50-025-20-0050-089	1	SHCS, 1/4-20 X .500
9	50-031-18-0075-089	6	SHCS, 5/16-18 X .750
10	50-050-13-0150-089	16	SHCS, 1/2-13 X 1.500
11	50-050-13-0175-055	32	SHCS, 1/2-13 X 1.75
12	05-050-13-0350-055	4	SHCS, 1/2-13 X 3.50
13	51-063-11-0150-089	4	FHSCS, 5/8-11 X 1.500
14	52-025-20-0050-088	12	FBHSCS, 1/4-20 X .500
15	55-050-13-0125-088	16	SSS, 1/2-13 X 1.250
16	65-125-251-312-2	2	Pop-Rivet, Domed Head, 1/8 Dia. X .251"-.312" Range
17	67-088-0284-2	2	Pin, Clevis
18	68-150-0750-1	1	Pin, Positive Lockout-Tagout
19	81-025-1	1	Washer, 1/4" X 1.00" OD Fender
20	90-087-2	4	Ring, Extra Thick Retaining
21	95-025-150-1	1	Key, 1/4" Square

*Recommended spare parts. Available in standard repair kit.

ITEM #	PART NUMBER	QTY	DESCRIPTION
22	99-150-300-2	1	Tag, Identification
23*	108-172-00-095	8	Seal, Cavity
24*	108-181-00-093	8	Seal, Quarter
25*	108-186-00-090	12	Blade, Seal Scraper
26*	180-187-00-090	2	Blade, Secondary Seal Scraper
27*	108-189-00-090	2	Blade, Primary Seal Scraper
28	108-270-00-054	1	Screw, Assembly
29	108-274-00-069	1	Disc, Thrust
30	108-277-00-054	1	Washer, Thrust
31	108-280-00-069	1	Bearing, Thrust
32	7108-015-00-006-J	2	Body, Double Block and Bleed Front
33	7108-030-00-053-J	1	Body, Double Black and Bleed Center
34	7108-050-00-053-K	1	Gate, Double Block and Bleed
35	7108-051-00-53-K	1	Gate, Double Block and Bleed
36	7108-220-00-076	1	Yoke, Double Block and Bleed Left
37	7108-230-00-076	1	Yoke, Double Block and Bleed Right
38	7108-240-00-075	2	Cover, Double Block and Bleed Dust
39	7108-260-00-062	1	Nut, Screw
40	7108-410-00-076	1	Plate, Bevel Gear 3
41	9000-250	1	2-1/2 Hollow Pipe Plug, B16.14
42	BG3	1	Bevel Gear Reducer, 3:1
43	HWRR18 11-322	1	Handwheel, 18" Round Recessed

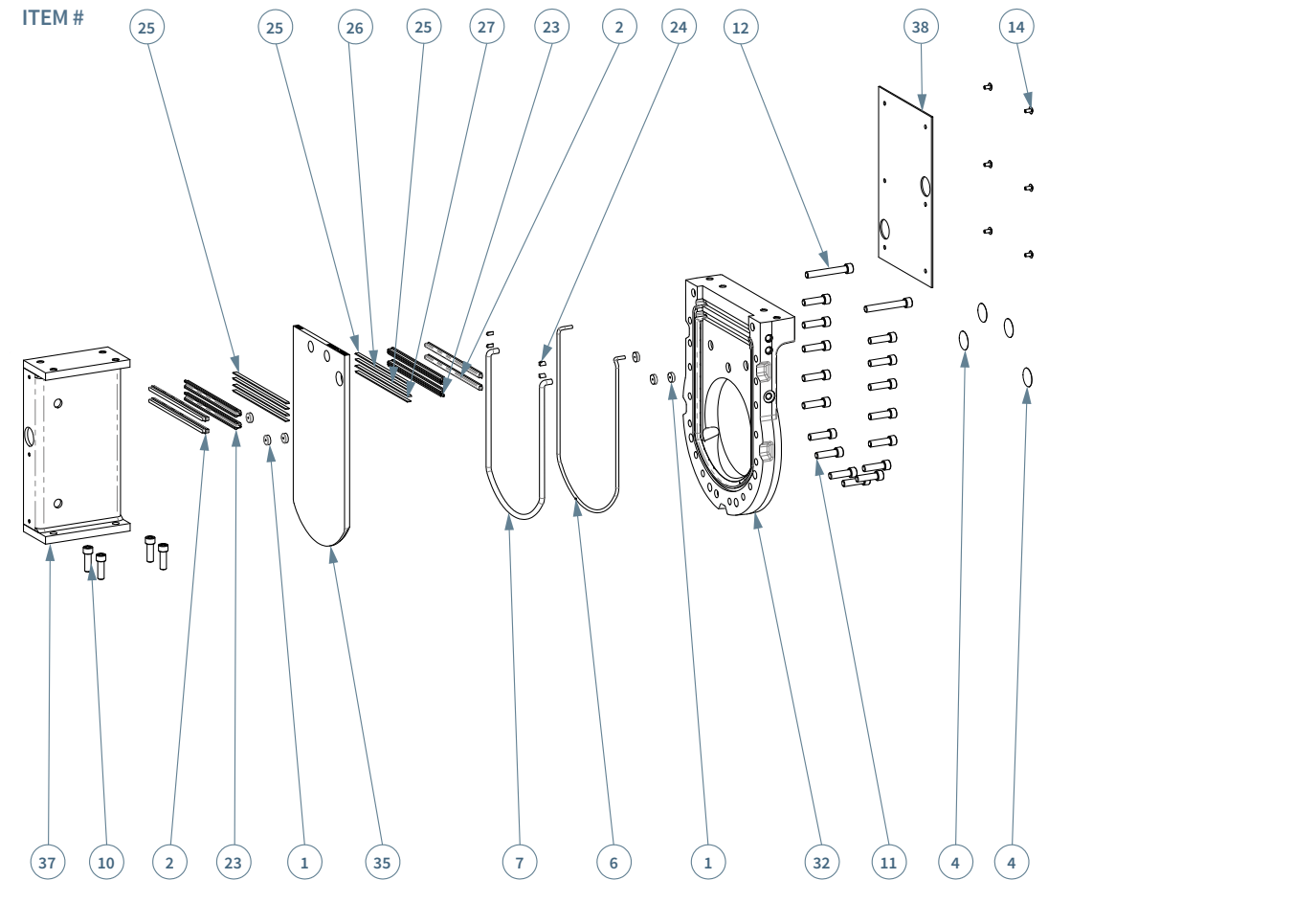

Double Block and Bleed Dimensions

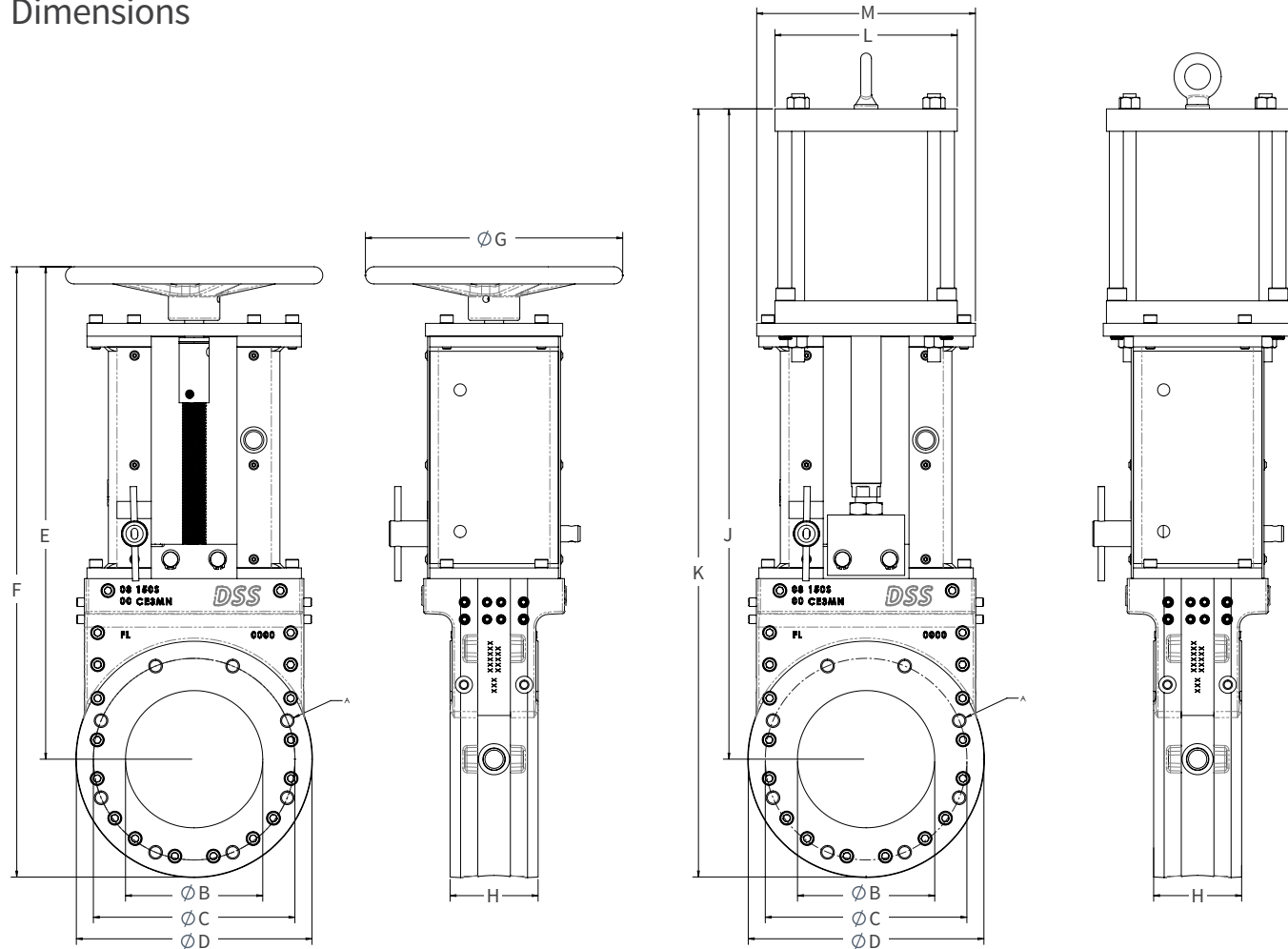

DBB SSKGV CLASS 150 DIMENSIONS																		
Valve Size			Flange					Dimensions										Standard Pneumatic Cylinder Bore**
			Bolting		Dimensions			Dimensions										
NPS*	DN [mm]	Class	QTY.	ØA (THREAD)	ØA (CLEARANCE)	ØB	ØC	ØD	E	F	ØG	H	J	K	L	M		
2	50	150	4	5/8-11	0.75	1.88	4.75	6.00	14.60	17.60	10.00	3.75	18.57	21.57	4.50	5.50	4.00	
3	75		4	5/8-11	0.75	2.88	6.00	7.50	16.60	20.35	10.00	3.75	21.76	25.51	4.50	5.50	4.00	
4	100		8	5/8-11	0.75	4.00	7.50	9.00	18.58	23.08	10.00	3.75	24.76	29.26	6.50	6.25	6.00	
6	150		8	3/4-10	0.88	6.00	9.50	11.00	23.29	28.79	12.00	4.00	31.93	37.43	8.50	10.25	8.00	
8	200		8	3/4-10	0.88	8.00	11.75	13.50	29.33	36.08	12.00	5.13	37.91	44.66	10.63	12.75	10.00	
10	250		12	7/8-9	1.00	10.00	14.25	16.00	33.19	41.19	12.00	5.13	43.64	51.64	12.75	14.50	12.00	
12	300		12	7/8-9	1.00	12.00	17.00	19.00	32.64	42.14	16.00	5.75	50.65	62.52	14.75	16.75	14.00	
14	350		12	1-8	1.12	13.25	18.75	21.00	-	-	-	5.75	55.81	66.34	17.00	19.00	16.00	
16	400		16	1-8	1.12	15.25	21.25	23.50	-	-	-	6.50	62.08	73.87	17.00	21.75	16.00	
18	450		16	1 1/8-8	1.25	17.25	22.75	25.00	-	-	-	6.50	68.08	80.63	17.00	24.00	16.00	
20	500		20	1 1/8-8	1.25	19.25	25.00	27.50	-	-	-	8.13	74.83	88.58	21.00	26.25	20.00	
24	600		20	1 1/4-8	1.38	23.25	29.50	32.00	-	-	-	8.13	86.95	102.95	23.00	30.25	22.00	
30	750		28	1 1/4-8	1.38	29.25	36.00	38.75	-	-	-	12.25	103.58	122.96	-	36.25	26.00	
36	900		32	1 1/2-8	1.63	35.25	42.75	46.00	-	-	-	14.75	125.70	148.70	-	43.00	32.00	

*Please consult DSS Valves or an authorized distributor for bore sizing, actuator sizing or specialty orders. Larger sizes and higher pressure classes are available upon request.



Design Specs, Material List and Torque Values

DESIGN SPECIFICATIONS

All DSS Valves meet the following design and build specifications:

- API 598
- ASME 16.34
- ASME 16.47
- ASME 16.5
- MSS SP-25
- MSS SP-55
- MSS SP-81
- MSS SP-135
- MSS SP-151
- MSS SP-152

Torque =
 (Nut Factor) * (Clamp Load) *
 (Thread Major Diameter)

Gasket Load =
 (Number of Bolts) * (Clamp Load)

Gasket Stress =
 (Gasket Load) / (Gasket Area)

MATERIALS					
Code	Cast		Wrought		Common Name
	Standard/Grade	UNS	Standard/Grade	UNS	
17	A747 CB7Cu-1	J92180	A693	S17400	17-4 PH
22	A995 Gr. 4A CD3MN	J92205	A240	S31803	Duplex 2205
25	A995 Gr. 5A CE3MN	J93404	A240	S32750	Super Duplex 2507
31	-	-	B625	N08031	Alloy 31/Nicrofer 3127 hMo
37	A351 CG8M	J93000	A240	S31700	317 SS
94	-	-	B625	N08904	904L
6X	A351 CN3MN	J94651	A240/B688	N08367	AL6XN
A2	A351 CN7M	N08007	B463	N08020	Alloy 20
CS	A216 WCB	J13345	A516 Gr. 70	-	Carbon Steel
DI	A536 65-45-12	F33100	-	-	Ductile Iron
DN	A439 D2	F43000	-	-	Ni-Resist D2
HC	A494 CW12MW	N30002	B575	N10276	Hastelloy C-276
NI	A436 Gr. 1	F41000	-	-	Ni-Resist 1
SS	A351 CF8M	J92900	A240	S31600	316 SS
T2	B367 Gr. C-2	R50400	B265 Gr. 2	-	Titanium Gr.2
T5	B367 Gr. C-5	R56400	B265 Gr. 5	-	Titanium Gr.5
T8	B367 Gr. C-8	R54810	B265 Gr. 8	-	Titanium Gr.8
TT	B367 Gr. C-12	R53400	B265 Gr. 12	-	Titanium Gr.12
XX	-	-	-	-	Other

TORQUE VALUES TO INDUCE BOLT STRESS									
Thread Major [in]	Threads/ Inch	Tensile Stress Area [in^2]	Nut Factor [K]	30,000 psi		45,000 psi		60,000 psi	
				Torque [ft-lbf]	Clamp Load [lbf]	Torque [ft-lbf]	Clamp Load [lbf]	Torque [ft-lbf]	Clamp Load [lbf]
0.625	11	0.226	0.19	67	6780	101	10170	134	13560
0.75	10	0.3345	0.177	111	10034	166	15051	222	20068
0.875	9	0.4617	0.175	177	13852	265	20778	354	27704
1	8	0.6057	0.178	270	18172	404	27259	539	36345
1.125	8	0.7905	0.173	385	23714	577	35571	769	47427
1.25	8	0.9997	0.172	537	29991	806	44987	1075	59983
1.375	8	1.2335	0.171	725	37005	1088	55508	1450	74010
1.5	8	1.4918	0.152	850	44755	1276	67133	1701	89511

Ordering Information

Severe Service Knife Gate Valve and Double Block and Bleed

TYPE	SERIES	FLANGE	SIZE	BODY	GATE
------	--------	--------	------	------	------

TYPE	P/N
Double Block and Bleed	DB
Severe Service Knife Gate	SV
Transmitter Isolation Valve	TV

SERIES	P/N
Class 150	1
Class 300	3
Class 600	6

FLANGE	P/N
SP 135 Short, ASME B16.5 [2" to 24"]	S
SP 135 LONG, ASME B16.5 [2" to 24"]	L
SP 135 Short, ASME B16.47 [26" to 60"] Series A	S
SP 135 Long, ASME B16.47 [26" to 60"] Series A	L
ASME B16.47 [26" to 60"] Series B	J
AS 2129 - Table D	D
AS 2129 - Table E	E
DIN 2501 - PN10	T
DIN 2501 - PN16	U
DIN 2501 - PN25	V
DIN 2501 - PN40	W

*Maximum pressure rating of valve will not exceed the ratings for the flange standard selected.

SIZE	P/N
1 inch	01
1.5 inch	1H
2 inch	02
2.5 inch	2H
3 inch	03
4 inch	04
5 inch	05
6 inch	06
7 inch	07
8 inch	08
10 inch	10
12 inch	12
14 inch	14
16 inch	16
18 inch	18
20 inch	20
22 inch	22
24 inch	24
26 inch	26
28 inch	28
30 inch	30
32 inch	32
36 inch	36
40 inch	40
42 inch	42
48 inch	48
60 inch	60
Other (specify)	XX

BODY MATERIAL	P/N
17.4 PH [A747 CB7Cu-1]	17
316 SS [A351 CF8M]	SS
317 SS [A351 CG8M]	7S
AL6XN [A351 CN3MN]	6X
Alloy 20 [A351 CN7M]	A2
Carbon Steel [A216 WCB]	CS
Cast Iron [A536 65-45-12]	CI
Duplex 2205 [A995 Gr. 4A CD3MN]	22
Hastelloy C-276 [A494 CW12MW]	HC
Ni-Resist 1 [A436 Gr. 1]	NI
Ductile Ni-Resist D2 [A439 D2]	DN
Super Duplex 2507 [A995 Gr. 5A CE3MN]	25
Titanium Grade 2 [B367 Gr. C-2]	T2
Titanium Grade 5 [B367 Gr. C-5]	T5
Titanium Grade 7 [B367 Gr. C-7]	T7
Titanium Grade 8 [B367 Gr. C-8]	T8
Titanium Grade 12 [B367 Gr. C-12]	TT
Aluminum	AL
Other (specify)	XX

GATE MATERIAL	P/N
17.4 PH [A693]	17
316 SS [A240]	SS
AL6XN [A240/B688]	6X
Carbon Steel [A516 Gr. 70]	CS
D55 Tool Steel	D5
Duplex 2205 [A240]	22
Hastelloy C-276 [B575]	HC
Super Duplex 2507 [A240]	25
Titanium Grade 2 [B265 Gr. 2]	T2
Titanium Grade 5 [B265 Gr. 5]	T5
Titanium Grade 7 [B367 Gr. C-7]	T7
Titanium Grade 8 [B265 Gr. 8]	T8
Titanium Grade 12 [B265 Gr. 12]	TT
Aluminum	AL
Other (specify)	XX

VALVE SEALS	SCRAPERS	ACTUATION	CYLINDER SIZE	ACT. SEALS	OPTION	OPTION	OPTION
-------------	----------	-----------	---------------	------------	--------	--------	--------

SEALS	P/N
Aflas [25 to 450°F] [-4 to 230°C]	AF
Buna N [-30 to 250°F] [-34 to 121°C]	BN
Chemraz [-20 to 600°F] [-28 to 315°C]	CH
EPDM [-65 to 265°F] [-54 to 129°C]	EP
GFLT Viton [-29 to 437°F] [-34 to 225°C]	GF
Graphite [Temperature limited by valve body materials]	GR
Polyurethane [-30 to 180°F] [-34 to 82°C]	PL
Teflon [-328 to 500°F] [-200 to 260°C]	TF
Viton [-15 to 437°F] [-26 to 225°C]	VI
Special (specify)	XX

SCRAPERS	P/N
Phenolic	1
Stainless	2
Brass	3
Special (Specify)	0

ACTUATION	P/N
Bare Yoke	BY
Bevel Gear	BG
Chainwheel	CW
Electric Actuator	EA
Gate & Body Only	GB
Gear Operator	GO
Handwheel	HW
Hydraulic Cylinder	HC
Low Profile	LP
Oversize Handwheel	OH
Pneumatic Cylinder	PC
Ratchet Handle	RH
Spring Extend [Fail Close]	SC
Spring Return [Fail Open]	SO

ACTUATION SEALS	P/N
Standard [-30°F to 250°F] [-34 to 121°C]	S
Low Temp [-50°F to 250°F] [-46 to 121°C]	L

BUILD OPTIONS	
Wear Ring (Inlet & Outlet)	S1
Wear Ring (Inlet)	S2
Bore Reducer (Inlet & Outlet)	S3
Bore Reducer (Inlet)	S4
V-Port	S5
Drilled Through Flange Holes	S6
Chest Relief	S7
Gate Guide Modification	S8
Purge Ports (Chest)	S9
Purge Ports (Nose)	S10
Stainless Steel Top Structure (304)	S11
Stainless Steel Top Structure (316)	S12
Stainless Steel Bolts (316)	S13
Stainless Steel Bolts (304)	S14
Stellite Tipped Gate	S15
Hardchrome Gate	S16
Hardfaced Port	S17
Raised Face Flange	S18
Xylan Bodies & Gate	S19
Xylan Gate	S20
Special Paint TopWorks	S21
Special Paint Actuator	S22
Limit Switches	S23
Proximity Switches [HAWKEYE]	S24
Positioner	S25
Position Indicator	S26
Control Solenoid	S27
Chrome Carbide Gate Nose	S28
UNC Flange Threads	S29
Lifting Lugs	S30
Extended Flushout Ports	S31
Prox/Limit Switch Prep only	S32
Reed Switch Cylinder Prep	S33
Metal Bonnet Covers (304SS)	S34
Manual Override	S35
Internal Transducer [Baluff]	S36
Internal Transducer [ROTA]	S37
Rod boot (Cylinder)	S38
Stem boot (Manual)	S39
Body material compatible drain plugs (DBB Valves)	S40
Other (Specify)	S99



ISO 9001:2015 Certified

“I have been consulting and auditing since 2000 and have never come across a company as young as DSS Valves successfully obtaining their ISO certification. The fact that they were able to complete this so quickly highlights both the level of expertise the founders provide and the company-wide belief in consistently producing a high quality product.”

Debra Hay Hampton
LA Lead Auditor—QMS

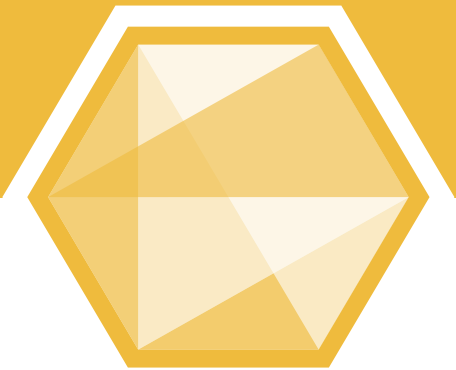

Contact Us

DSS Valves
1760 Mayflower Road
Niles, MI 49120
USA

TEL: 269-409-6080
FAX: 269-409-6099
info@dssvalves.com
DSSVALVES.COM