

Dependable safety valve to retain a set supply air pressure and guarantee a steady process control when a supply air is suddenly failed by accident and its pressure becomes lower than a set pressure



LUS



LUD

Specifications

	LU	
	LUS	LUD
Proof Pressure	Max 10 kgf/cm ² (150psi)	
Signal Pressure	1.4 ~ 7 kgf/cm ²	
Line Pressure	Max 7 kgf/cm ² (105psi)	
Flow Capacity (Cv)	0.9	
Operating Temperature	-20°C ~ +70°C *	
Pneumatic Connections	PT(Rc) 1/4 or NPT 1/4	
Hysteresis	Within 0.1 kgf/cm ²	
Body Material	Aluminum die-cast	
Weight	0.6 kg	0.8 kg

* High temperature option : up to +120 °C

How to Order

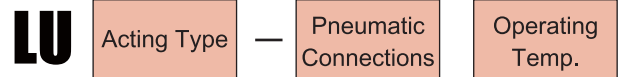

Description	Code
Acting Type :	S : Single acting D : Double acting
Pneumatic Connections :	1 : PT (Rc) 1/4 2 : NPT 1/4
Operating Temperature :	1 : -20 ~ +70°C (standard) 2 : -20 ~ +120°C (high temp.)

Dimensions

< LUS >

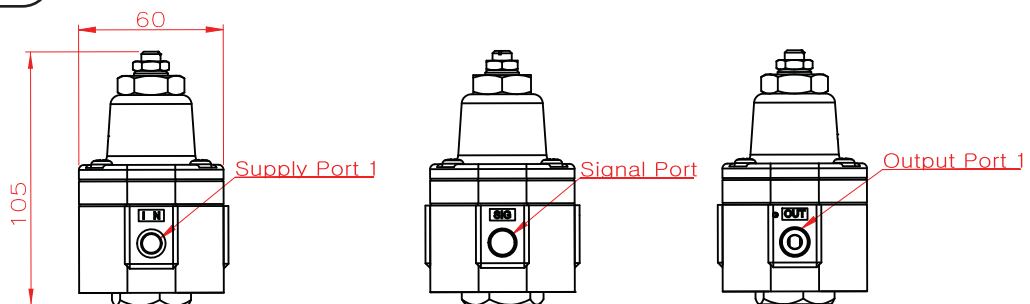

< LUD >

