

Perfect combination with reliable fail freeze function and smart performance with innovative durable coil drive

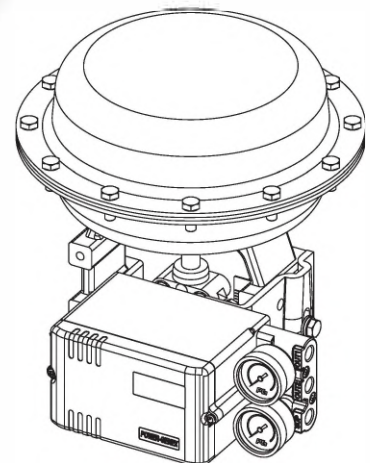

Features

- ▶ “Fail Freeze” function to help the valve stay at the last position on the electrical power supply or the pneumatic supply air by accident
- ▶ Easy and quick auto-calibration
- ▶ Detecting RA (reverse acting) or DA (direct acting) automatically regardless of wrong air connections
- ▶ Available to use for single or double acting without any special adjustments
- ▶ Compact design allowing to be installed on small actuators
- ▶ Providing error messages against performance failures
- ▶ Possible to test the actuator with any fixed signal under a test mode
- ▶ Programmable characteristic curve with 17 points
- ▶ Wide operating temperature range -30 ~ +80 °C
- ▶ Improved control of high-friction globe and ball valves by eliminating an overshoot and a hunting
- ▶ Low air consumption
- ▶ Providing a mounting bracket to meet IEC 60534-6-1 for linear valves
- ▶ Supporting a NAMUR mounting pattern VDI/VDE 3845 (IEC 60534-6-2) and providing a multi-size mounting bracket for rotary valves



- SS5L (Linear Type)

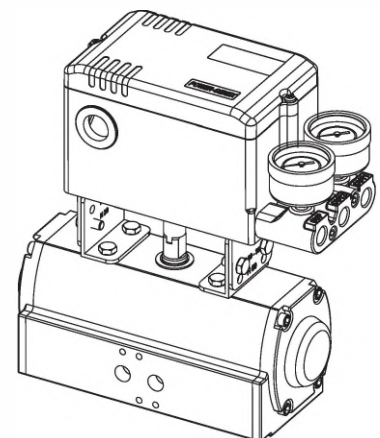

- SS5R (Rotary Type)

Options

- ▶ Output position transmitter (4 - 20 mA)
- ▶ 2 x alarm limit or micro switch (SPDT)
- ▶ Explosion proof type (IECEX / ATEX / KC Ex ia IIC T6/T5 - in progress)
- ▶ HART communication
- ▶ Profibus communication (in progress)
- ▶ Fieldbus Foundation communication (in progress)

Specifications

Input Signal	4 - 20 mA @ 24 VDC
Min. / Max. Current	3.6 mA / 50 mA
Voltage Drop (Resistance)	Without Hart : 8.9 VDC (445Ω @ 20 mA) With Hart : 9.4 VDC (470Ω @ 20 mA)
Stroke / Angle	Linear type : 5 - 130 mm * Rotary type : 25 - 120°
Air Supply Pressure	1.4 - 7 bar (20 - 100 psi), filtered, compressed dry and non-oiled to meet Class 3 of ISO 8573-1
Output Pressure Range	0 - 100% of supply air pressure
Air Capacity	80 ℓ/min = 4.8 N ^m /h = 2.8 scfm (Sup = 1.4 bar) 233 ℓ/min = 14 N ^m /h = 8.2 scfm (Sup = 6 bar)
Air Consumption	2 ℓ/min = 0.12 N ^m /h = 0.07 scfm (Sup = 1.4 ~ 6 bar)
Characteristic	Linearity < ±0.3% F.S Sensitivity < 0.2% F.S Hysteresis < 0.2% F.S Repeatability < 0.2% F.S
Performance Characteristic	Linear, EQ %, Quick open, User set (17 points)
LCD Indication	4-digit LCD indicator
Adjustable Speed	1 - 1000 (lowest 1, highest 1000)
Scan Time	2ms
Shut-off Value	Range 0 - 10% of position signal
Valve Action	Direct action (DA) / Reverse action (RA)
Operating Temperature	- 30 ~ +80 °C (- 22 ~ +176 °F) **
Pneumatic Connections	PT(Rc) 1/4 or NPT 1/4
Electrical Connections	2 x PF(G) 1/2, NPT 1/2, M20 x 1.5
Protection Class	IP66, intrinsically safe (IECEX / ATEX / KC Exia IIC T6/T5)
Body Material	Aluminum die-cast / powder-painted
Weight	1.6 kg

* Up to 200mm on request ** -40 °C on request

Principle of Operation

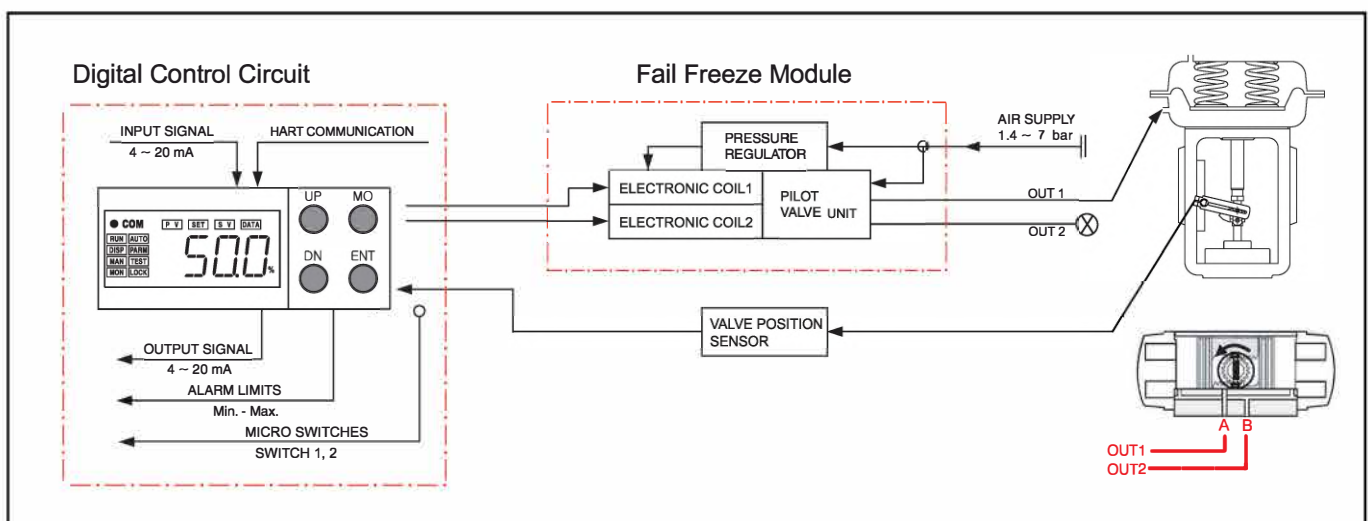

If 4-20mA input signal is supplied, the microprocessor compares the input signals and the feedback values and send the control signals to the I/P converter. A supply air is converted to the pneumatic signals by two electronic coils and moves the pilot valve until the control valve reaches the desired position. In case of a signal failure or a supply air failure, a venting air is blocked inside of the pilot valve and the valve stays at the last position because of an existing supply air pressure between the positioner and the actuator.

Smart Valve Positioner (fail freeze function)

SS5 Linear / Rotary

SS5 Front Cover Removed

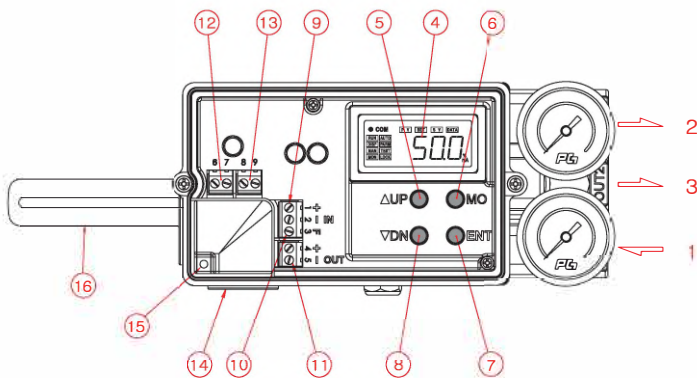

- 1 : Air supply
- 2 : OUT 1
- 3 : OUT 2
- 4 : Display LCD
- 5 : Up key
- 6 : Mode key
- 7 : Enter key
- 8 : Down key
- 9 : Input signal (+, -)
- 10 : Frame ground
- 11 : Output signal (+, -)
- 12 : Alarm limit 1
- 13 : Alarm limit 2
- 14 : Electrical connections
- 15 : Ground
- 16 : Feedback lever

Electrical Connections

- 1 (+) → IN. 4-20mA input signal
- 2 (-) → Frame Ground
- 3 (FG) → Frame Ground
- 4 (+) → OUT. 4-20mA output signal
- 5 (-) → OUT. 4-20mA output signal
- 6 (+) → LS1. (Low) Alarm limit 1
- 7 (-) → LS1. (Low) Alarm limit 1
- 8 (+) → LS2. (High) Alarm limit 2
- 9 (-) → LS2. (High) Alarm limit 2

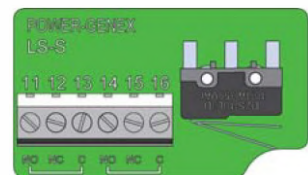
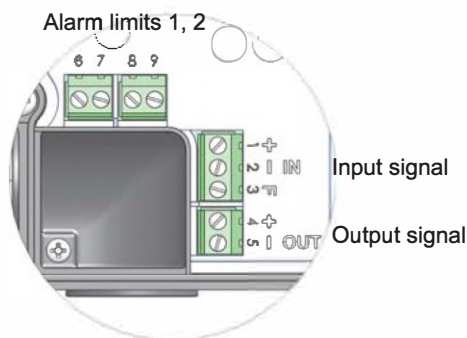

Micro switches 1, 2

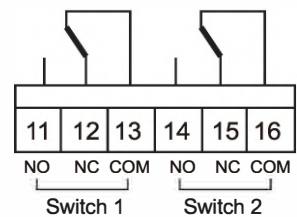

How to Order

SS5 Actuator Operation — Protection Class Feedback Lever Pressure Gauges Position Feedback Communication Connection Threads Mounting Bracket Feedback Pin Guide Lever Set

Description	Code
Actuator Operation :	L : Linear type R : Rotary type
Protection Class :	I : Intrinsically safe (IECEX Ex ia IIC T6/T5, ATEX Ex ia IIC T6/T5) K : Intrinsically safe (KC Ex ia IIC T6/T5) W: Weatherproof to IP66
Feedback Lever : - Linear Type	A : Stroke (5 ~ 30mm) B : Stroke (5 ~ 65mm) C : Stroke (5 ~ 130mm) D : Stroke (80 ~ 200mm)
- Rotary Type	F : Fork lever N : Namur shaft (direct mounting)
Pressure Gauge Block :	0 : Not mounted 1 : 6 bar (90 psi) 2 : 10 bar (150 psi)

Description	Code
Position Feedback :	N : None O : Position transmitter (4 ~ 20mA output signal) L : 2 x alarm limit S : 2 x micro switch (SPDT) M : O+L Q : O+S
Communication :	N : None H : HART
Connection Threads : (pneumatic - electrical)	3 : PT(Rc) 1/4 – PF(G)1/2 4 : NPT 1/4 – NPT 1/2 5 : PT(Rc) 1/4 – M20 x 1.5
Mounting Bracket :	N : None L : IEC 60534-6-1 (for SS5L) R : VDI/VDE 3845 / IEC 60534-6-2 (for SS5R)
Feedback Pin Guide Lever Set : (only for linear type SS5L)	0 : Not included 1 : Included

Dimensions

- SS5L (Linear Type)

Electrical connections
2 - PF(NPT)1/2

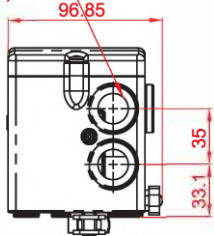

Electrical connections
PF(NPT)1/2

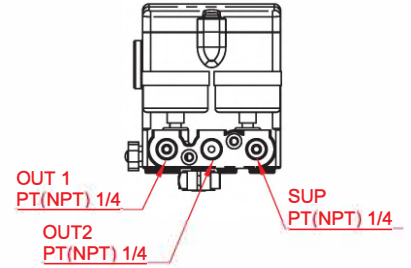
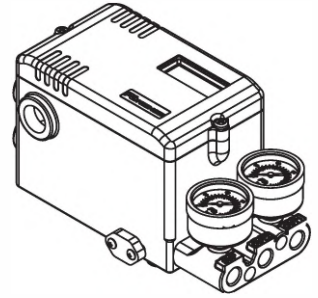
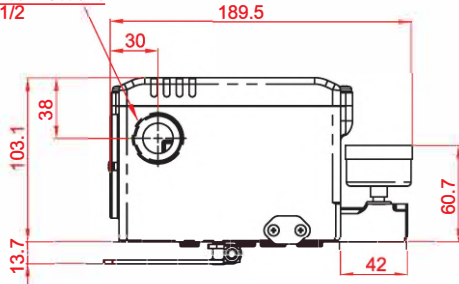

A,B,C,D TYPE LEVER

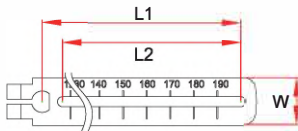

LEVER TYPE	L1(mm)	L2(mm)	W(mm)
A	30	21.40	20
B	65	55.90	20
C	130	121.40	20
D	200	191.40	20

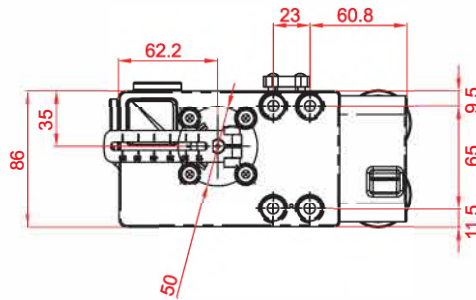

- SS5R (Rotary Type)

Electrical connections
2 - PF(NPT)1/2

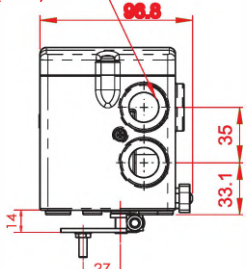

< Fork Lever Type >

Electrical connections
PF(NPT)1/2

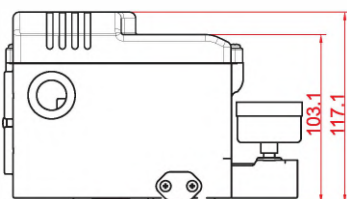
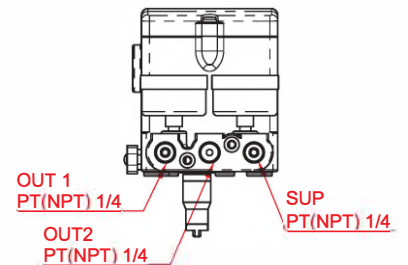
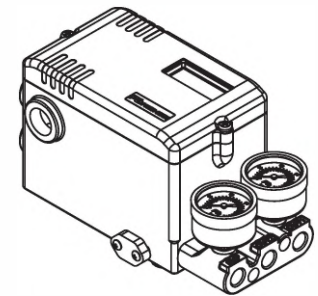
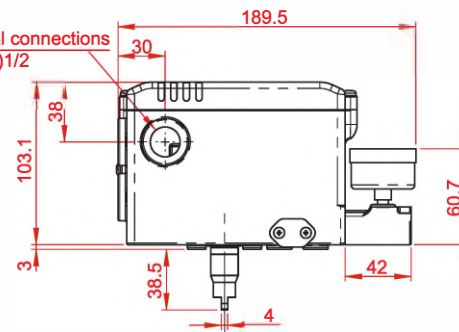

< SS5 with 2 x SPDT Micro S/W >

