

STRAUB-OPEN-FLEX 2 | Ø 172.0 - 2032.0 mm

Components / Materials	W1	W2	W4	W5
Casing	S355MC, hot-dip galvanised	AISI 316 L or similar		AISI 316 L or similar
Bolts	AISI 4135	AISI 4135		A4 - 80
Bars	AISI 12L14, galvanised	AISI 12L14, galvanised		AISI 316 L or similar
Strip insert (option)	AISI 316 L or similar / HDPE	AISI 316 L or similar / HDPE		AISI 316 L or similar / HDPE
Sealing sleeve EPDM	Temp.: -20°C up to +100°C Medium: all qualities of water, waste water, air, solids and chemical products			
Sealing sleeve NBR	Temp.: -20°C up to +80°C Medium: water, gas, oil, fuel and other hydrocarbons			
Sealing sleeve FPM/FKM	Temp.: -20°C up to +180°C Medium: ozone, oxygen, acids, gas, oil and fuel (only with strip insert)			

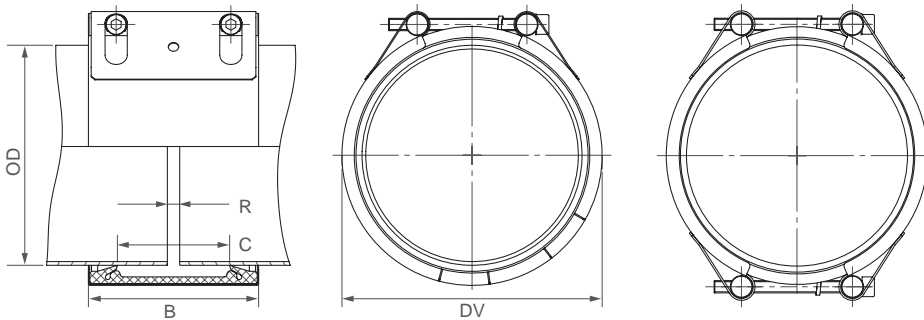

B ⇔ 138 up to 148 mm
 DV ⇔ OD + 27 mm
 C ⇔ 91 mm
 R with strip insert ⇔ 35 mm
 R without strip insert ⇔ 10 mm

	W2 or W5
	W1, W2 or W5
	W1 or W5
	only in W1 available

OD [mm]	Clamping range [mm]	PN					PN [bar]
		2.5	6	10	16	20	
172.0	170 - 174						
180.0	178 - 182						
200.0	198 - 202						
219.1	217 - 222						
250.0	248 - 253						
267.0	264 - 270						
273.0	270 - 276						
304.0	301 - 307						
323.9	321 - 327						
355.6	353 - 358						
406.4	404 - 409						
457.2	454 - 460						
508.0	505 - 511						
558.8	556 - 562						
609.6	606 - 613						
711.2	708 - 715						
762.0	758 - 766						
812.8	809 - 817						
914.4	910 - 918						
1016.0	1012 - 1020						
1117.6	1114 - 1122						
1219.2	1215 - 1224						
1320.8	1316 - 1325						
1422.4	1418 - 1427						
1524.0	1519 - 1529						
1600.0	1595 - 1605						
1625.6	1621 - 1631						
1727.2	1722 - 1732						
1828.8	1824 - 1834						
1930.4	1925 - 1935						
2032.0	2027 - 2037						

Pressure rates according to type approval

CONTINUOUSLY VARIABLE INTERMEDIATE SIZES FROM 172.0 TO 2032.0 mm ARE AVAILABLE

Remarks:

- Follow fitting instructions
- PN (🏭) = working pressure considering the application loads
Test pressure = PN (🏭) x 1.5 (e.g. industry, water supply etc.)
PN (🚢) = nominal pressure, includes four times safety factor (e.g. shipbuilding)
- Strip inserts are optional accessories (see Technical Manual STRAUB)
- Additional sealing sleeves, pressure and temperature ranges on request

Versions:

2.5	6	PN				1 piece (slotted) [mm]	2 piece casing [mm]
		10	16	20	25		
x	x					≤ 1219.1	on order
x	x					> 1219.1	on order
		x				172.0-355.6	on order
		x				355.6-457.2	on order
		x				457.2-711.2	on order
		x				> 711.2	on order
			x			≤ 219.1	on order
			x			219.1-1524.0	on order
				x		172.0-1016.0	on order
					x	180.0-762.0	on order