

Forged steel bonnetless Y-pattern valves



**ASME CLASSES:
1690-4500
NPS: 1/4 - 4
(DN 8-100)**



Easy maintenance!

VELAN

VELAN'S PROFILE

VELAN AT A GLANCE

History

- Founded in 1950

People

- Over 2,000 employees

Product line

A world-leading range of valves across all major industrial applications:

- Cast steel gate, globe, check, and ball valves
- Forged steel gate, globe, check, and ball valves
- Triple-offset butterfly valves
- Knife gate valves
- Severe service valves
- Bellows seal valves
- Steam traps

Primary industries served

- Fossil, nuclear, and cogeneration power
- Oil and gas
- Refining and petrochemicals
- Chemicals and pharmaceutical
- LNG and cryogenics
- Marine
- HVAC
- Mining
- Water and wastewater
- Pulp and paper
- Subsea

Velan holds major applicable approvals:

- ASME Section III N and NPT for nuclear valves (since 1970)
- ISO 9001 (since 1991) and ISO 14001
- OHSAS 18001
- PED
- SIL
- GOST
- API 6A and API 6D
- TA-Luft
- Comprehensive quality programs that are compliant with the most stringent industry standards such as ISO 9001, API Q1, NCA 4000, ASME NQA-1 and 10 CFR 50 Appendix B.
- Velan has been surveyed and audited by leading organizations around the world such as Bureau Veritas, API, ASME, NUPIC, Newport News Shipbuilding, and DCMA.
- Total Process Improvement Program, including Lean Manufacturing and Six Sigma



Velan is one of the world's leading manufacturers of cast and forged steel gate, globe, check, ball, triple-offset, knife gate, highly engineered severe service valves, and steam traps offering superior performance across all major industrial applications including: fossil, nuclear, and cogeneration power; oil and gas; refining and petrochemicals; chemicals and pharmaceutical; marine; HVAC; mining; water and wastewater; pulp and paper; and subsea. The company also supplies actuators and integrated control packages.

Founded in 1950, Velan has earned a reputation for product excellence and innovation by bringing to the market superior products with special emphasis on quality, safety, ease of operation, and long service life. Velan valves have an extremely broad installation base and are approved by major companies worldwide.

Velan concentrates on one business—the design, manufacture and marketing of steel valves in a broad range of types and sizes for high performance service in a wide range of applications. The company's talented people are focused on Velan's core values of quality, reliability, innovation, and integrity and mission to be the world's leading valve brand.

TABLE OF CONTENTS

Velan profile and global network	2-3
Design features	4-5
Special services, live-loaded and bellows sealed valves	6-7
Forged steel bonnetless y-pattern globe valve dimensions and weights ..	8
Forged steel piston check valves for horizontal and vertical lines	9
Pressure-temperature ratings	10
How to order.....	11



VELAN'S GLOBAL NETWORK

Head office



Montreal, Canada
Velan Inc.

- 14 production facilities
- 4 plants in North America
- 5 plants in Europe
- 5 plants in Asia
- 4 stocking and distribution centers
- Hundreds of distributors worldwide
- Over 60 service shops worldwide

Manufacturing plants

North America



Montreal, Canada
Velan Inc., Plant 1



Montreal, Canada
Velan Inc., Plant 2 and 7



Granby, Canada
Velan Inc., Plant 4 and 6



Williston, VT, U.S.A.
Velan Valve Corp., Plant 3



Europe



Lyon, France
Velan S.A.S.



Mennecy, France
Segault S.A.



Lisbon, Portugal
Velan Válvulas Industriais, Lda.



Lucca, Italy
Velan ABV S.r.l., Plant 1



Lucca, Italy
Velan ABV S.r.l., Plant 2

Asia



Ansan City, South Korea
Velan Ltd., Plant 1



Ansan City, South Korea
Velan Ltd., Plant 2



Taichung, Taiwan
Velan Valvac Mfg. Co., Ltd.



Suzhou, China
Velan Valve (Suzhou) Co., Ltd.



Coimbatore, India
Velan Valves India Pvt. Ltd.

Distribution centers



Granby, Canada
VelCAN



Benicia, CA, U.S.A.
VelCAL



Missouri City, TX, U.S.A.
VelTEX



Willich, Germany
Velan GmbH

 – ASME N-stamp accredited manufacturer

VELAN FORGED STEEL BONNETLESS

FOR HIGH PRESSURE-TEMPERATURE SERVICE WITH LOW FUGITIVE EMISSIONS

Velan one-piece, forged, bonnetless globe valves have been proven in critical, tough service applications around the world for over 30 years. This includes high pressure drop, steam blow down, steam injection, fast acting isolation, 6,000 psi (414 bar) gas and super heated steam at 1,100°F (593°C). In 1981, after rigorous testing of valve performance and all its components, we redesigned the valve and added several new patented features. It is with pride that we offer to the user this outstanding, long-lasting, high performance valve for high-pressure and tough applications.

The only valve with 22 design features for high pressure steam and other tough services

1	BODY	All pressure-containing parts in one vessel
2		No body-bonnet gasket or pressure seal
3		Self-draining waterways (no deposits)
4	SEAT	Double orifice to better dissipate erosive flow energy through main seat
5		Suitable for blow down and blow off services
6	DISC	Fully-guided disc (bottom & top)
7		Non-spinning disc
8		Disc seating, guiding and stem contact in CoCr alloy
9	STEM	Non-rotating stem prevents torsional damage of packing and ensures low torque
10		Stem threads protected from dirt, dust, sand
11	STEM NUT	Fully enclosed and greased stem nut drive protected from dirt, dust, sand
12		Stem nut riding on 2 needle bearings
13		Position indicator as standard
14	PACKING CHAMBER	Packing chamber burnished for tight seal
15		Packing rings individually pre-stressed
16	PACKING GLAND	Optional live-loading of packing
17		Self aligning two-piece gland
18	BACK SEAT	CoCr alloy backseat
19		Backseating bevel on stem
20	SERVICING	No welds to cut for servicing
21		No threaded bonnet which can seize
22		One-step removal of all working parts including packing

The valve combines all these features:

- Best flow characteristics
- Best design and operational features
- Solid CoCr alloy guided, non-spinning disc
- Enclosed, dust and dirt protected stem
- Lowest operational torque
- Low maintenance cost
- Simplest and fastest method of in-line internal repairs

Non-spinning, body-guided solid CoCr alloy disc

- Disc is guided at bottom and top
- Tight fit in body ensures disc-seat alignment and prevents side thrust on stem
- No galling of body, scoring or bending of stem
- Large clearance between stem and disc allows disc to move freely
- Cannot detach from stem, as not used for backseating
- Stop, stop check or needle control disc
- Non-spinning feature due to two flats in bottom area inside of the disc

Unique, fully-enclosed stem nut drive

- Well lubricated stem nut, rotating on two thrust bearings
- 10,000 test cycles show no visible damage to parts
- Dust cover and sleeve protect stem threads from dirt, dust and sand

Heavy integral CoCr alloy seat

- Tight shut-off
- Long valve life
- Easy refacing

Double orifice

- Protects seating faces because part of the erosive flow energy dissipates through second orifice
- Allows use of standard valves in high-pressure drop blow down applications

Note: CoCr alloy as used throughout this catalog refers to cobalt chrome hardfacing alloys as supplied by Kennametal Stellite™, and other approved manufacturers.

ONE-PIECE Y-PATTERN GLOBE VALVES

DESIGNED FOR TOUGH SERVICE, LOW MAINTENANCE AND FAST IN-LINE INTERNAL REPAIRS

Non-rising handwheel

Valves also supplied with electric, pneumatic or gear actuators.

One-piece forged body

- No pressure-retaining threads or bolts
- No welds to cut and reweld

Streamlined flow and self-draining waterways

- Eliminates deposits and corrosion
- 65° incline reduces pressure drop

Quick and easy disassembly

No welds to remove

Non-rotating splined stem

Extra low operating and seating torques ensured by:

- Non-rotating stem
- No torsion applied to packing rings
 - Stem guided linearly in a low friction spline
 - No stem scoring or bending

Long-lasting, tighter stem packing for low fugitive emissions

- Non-rotating stem
- Rings precompressed to approx. 4,000 psi (275 bar)
- Combination graphite rings
- Heavy packing flange and bolting
- Live-loading optional

Two-piece positive backseat

- Separate CoCr alloy ring lapped against the body and seated against the stem bevel for positive shutoff
- Threaded, splined bushing guides the stem and allows easy removal of all internals

DISC OPTIONS

NEEDLE DISC

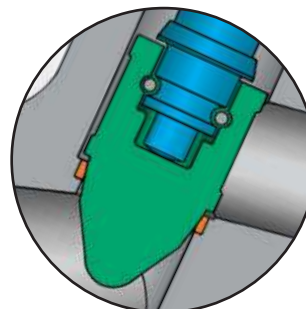

STOP CHECK DISC

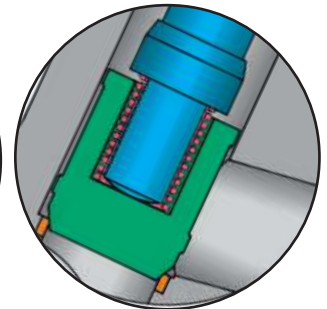

VELAN SPECIAL SERVICES

LIVE-LOADED Y-PATTERN GLOBE VALVES WITH DOUBLE PACKING, LEAK-OFF AND LIVE-LOADING

NPS ¼–4 (DN 8–100)

ASME CLASSES 1690, 2680, and 4500

DESIGN FEATURES

- **Non-rotating stem**

Non-rotating stem has close roundness and straightness tolerances and is burnished for a superior finish.

- **Heavy two-piece gland**

Packing gland is built to withstand high stresses caused by live-loading.

- **Live-loading**

Two sets of Belleville springs maintain a minimum permanent stress of 4,000 psi (275 bar) on graphite packing. Live-loading keeps packing tight for long periods of time without maintenance. Bolt torques control total spring load.

- **Double packing and leak-off**

A lantern ring and leak-off pipe provide for detection or removal of leakage, if any, from lower packing set (optional).

- **Short and narrow packing chamber**

Sealing effectiveness improves as overall packing length shortens. Chamber wall is burnished to a superior finish.

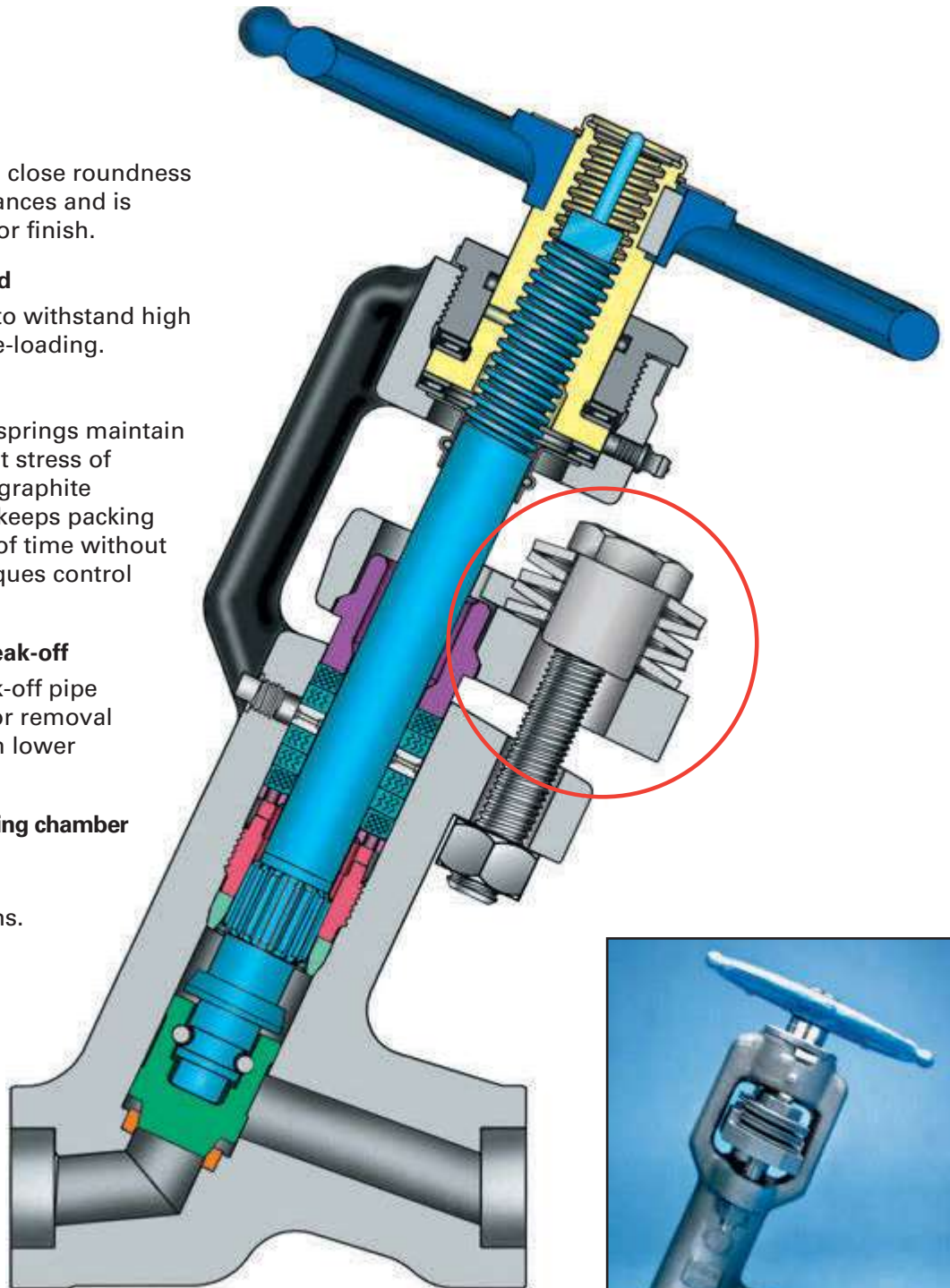

Note: Other features of bonnetless y-pattern globe valves on pages 4-5

VELAN SPECIAL SERVICES

BELLOWS SEAL HERMETICALLY-SEALED Y-PATTERN GLOBE VALVES

NPS ½–2 (DN 15–50)
ASME CLASSES 1500–2500

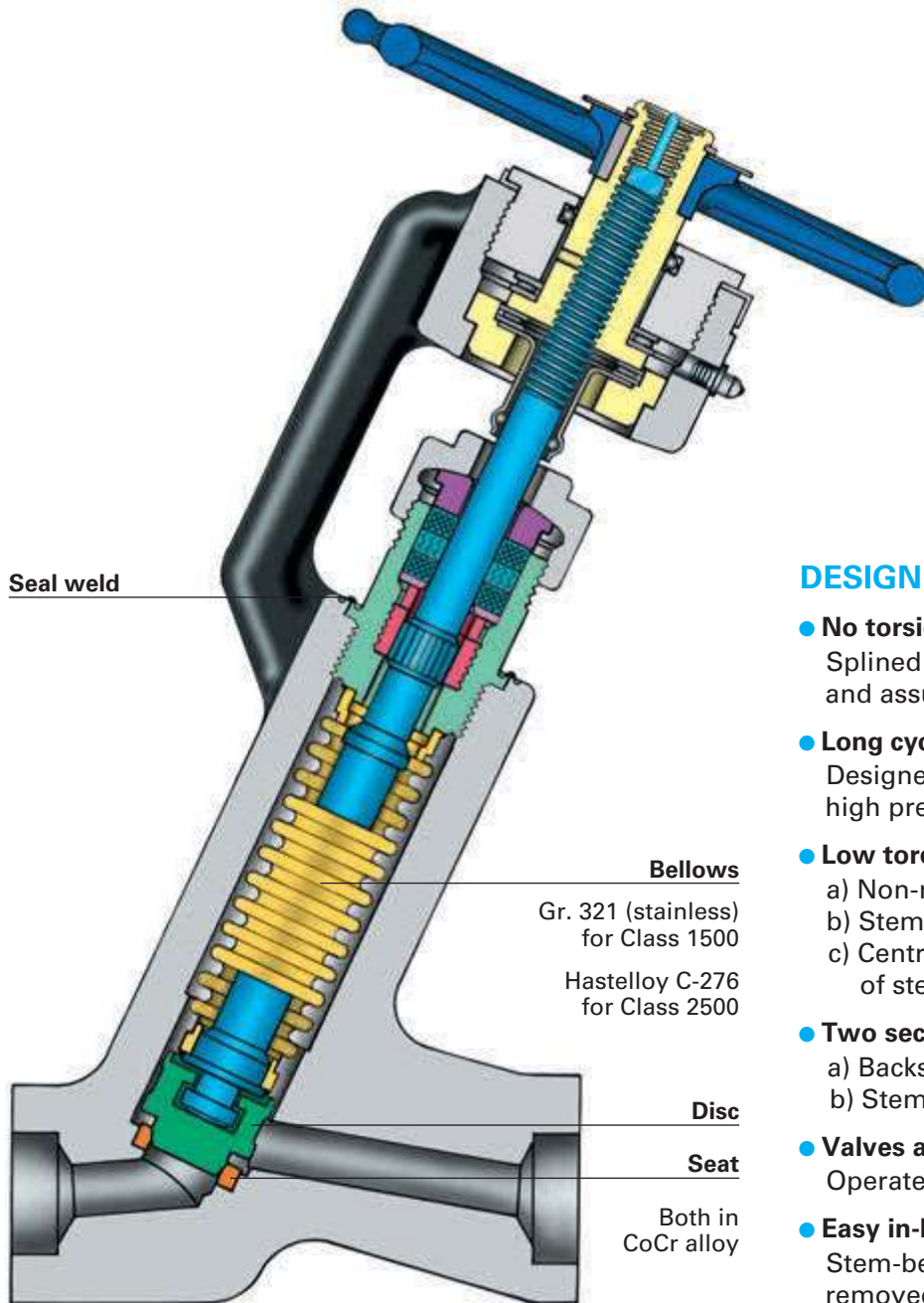

*In-service photo of Class 2500
hermetically-sealed
Y-pattern bellows seal valve.*

DESIGN FEATURES

- **No torsion of bellows**
Splined stem prevents torsion of bellows and assures long cycle life.
- **Long cycle life bellows (5,000 cycles)**
Designed for, and successfully tested in, high pressure–temperature conditions.
- **Low torque due to:**
 - a) Non-rotating stem
 - b) Stem nut thrust bearings
 - c) Central grease fitting for lubrication of stem nut.
- **Two secondary stem seals**
 - a) Backseat
 - b) Stem packing.
- **Valves are fire safe**
Operate normally during and after fire test.
- **Easy in-line servicing**
Stem-bellows assembly can easily be removed and replaced on valves with threaded (O-ring seal) bonnet. On seal-welded valves, removal and replacement of weld is necessary. Special power operated tools are available for cutting the seal weld.

For more information, see our *Bellows Seal Valves catalog (VEL-BS)* at www.velan.com

VELAN FORGED STEEL Y-PATTERN BONNETLESS GLOBE VALVES

CONVENTIONAL PORT OPENING, THREADED, SOCKET WELD, OR BUTT WELD
NPS ¼–4 (DN 8–100) ASME CLASSES 1690, 2680, 4500

STANDARD MATERIALS

Part	Materials		
Body	A105N	A 182 Gr. F22	A 182 Gr. F316
Seat (integral)	CoCr alloy	CoCr alloy	CoCr alloy
Disc	CoCr alloy	CoCr alloy	CoCr alloy
Stem	Gr. 410 (stainless)	Gr. 410 (stainless)	Gr. 316B (stainless)
Stem nut	A 439 Austenitic ductile iron Gr. D-2C		
Backseat	CoCr alloy	CoCr alloy	CoCr alloy
Splined bushing	Gr. 630 (stainless)	Gr. 630 (stainless)	Gr. 630 (stainless)
Packing washer	Gr. 304 (stainless)	Gr. 304 (stainless)	Gr. 304 (stainless)
Packing	Graphite	Graphite	Graphite
Split gland bushing	Gr. CA15 (stainless)	Gr. CA15 (stainless)	Gr. CA15 (stainless)
Packing flange	A105	A105	A182 Gr. F304
Gland stud	Gr. B7	Gr. B6	Gr. B8M2
Gland nut	Gr. 2H	Gr. 2H	Gr. 8M
Yoke bushing	Gr. 1020 steel	Gr. 1020 steel	Gr. 1020 steel (nickel plated)
Thrust bearing	Steel	Steel	Steel
Stem protector	Steel	Steel	Steel (nickel-plated)
O-ring	Nitrile rubber	Nitrile rubber	Nitrile rubber
Handwheel	Malleable iron (painted)	Malleable iron (painted)	Malleable iron (painted)
Snap ring	Steel	Steel	Steel
Name plate	Gr. 304 (stainless)	Gr. 304 (stainless)	Gr. 304 (stainless)

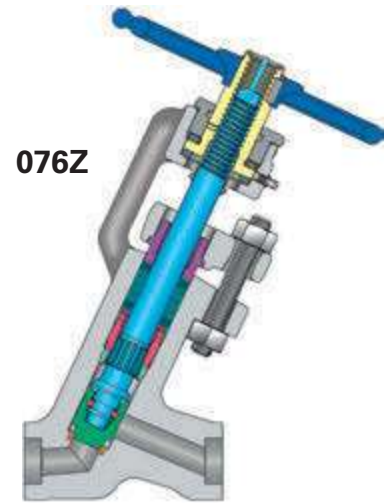

076Z

DESIGN SPECIFICATIONS

ITEM	APPLICABLE SPECIFICATION
General design	ASME B16.11
Socket weld design	ASME B16.11
Threaded design	ASME B1.20.1
Butt welding design	ASME B16.25
Testing	ASME B16.34 & MSS-SP-61
Marking	MSS-SP-25

DIMENSIONS, WEIGHTS AND CV

Size NPS DN	A Port		B End-to-end		C Center-to-top		H Handwheel		BP Clearance open		CF Center-to-end		Weight lb/kg		Cv Flow coefficient	
	1690 2680	4500	1690 2680	4500	1690 2680	4500	1690 2680	4500	1690 2680	4500	1690 2680	4500	1690 2680	4500	1690 2680	4500
¼ 8	0.559 14.2	0.375 9.5	4.88 124	5.75 146	9.63 146	11.75 298	6.00 152	6.00 152	3.63 92	3.25 83	3.20 81	4.19 106	15 7	27 12.2	1.3	1.0
¾ 10	0.559 14.2	0.375 9.5	4.88 124	5.75 146	9.63 245	11.75 298	6.00 152	6.00 152	3.63 92	3.25 83	3.20 81	4.19 106	15 7	27 12.2	2.4	1.3
½ 15	0.559 14.2	0.375 9.5	4.88 124	5.75 146	9.63 245	11.75 298	6.00 152	6.00 152	3.63 92	3.25 83	3.20 81	4.19 106	15 7	27 12.2	2.9	1.5
¾ 20	0.559 14.2	0.559 14.2	4.88 124	7.00 178	9.63 245	14.78 375	6.00 152	10.00 254	3.63 92	6.00 152	3.20 81	3.88 99	15 7	56 25	5.0	5.0
1 25	0.833 21.2	0.559 14.2	5.75 146	7.00 178	13.19 335	14.78 375	8.00 203	10.00 254	5.13 130	6.00 152	4.19 106	3.88 99	33 15	56 25	9.8	5.0
1¼ 32	1.125 28.6	0.833 21.2	7.25 184	10.13 257	16.63 422	18.88 480	12.00 305	12.00 305	7.57 192	7.00 178	4.94 125	6.57 167	67 30	94 43	20	9.8
1½ 40	1.125 28.6	1.125 28.6	7.25 184	12.00 305	16.63 422	20.75 527	12.00 305	18.00 457	7.57 192	8.00 203	4.94 125	8.00 203	67 30	148 67	20	20
2 ⁽¹⁾⁽³⁾ 50	1.688 42.9	1.125 28.6	10.13 257	12.00 305	19.73 501	20.75 527	12.00 305	18.00 457	7.50 190	8.00 203	6.57 167	8.00 203	110 50	148 67	60	26
2½ ⁽²⁾⁽³⁾⁽⁴⁾ 65	1.688 42.9	1.50 38.1	12.00 305	12.00 305	20.69 526	20.75 527	16.00 ⁽⁵⁾ 406	16.00 ⁽⁵⁾ 406	7.25 184	7.25 184	8.00 203	8.00 203	148 ⁽⁶⁾ 67	148 67	60	47
3 ⁽²⁾⁽⁴⁾ 80	1.688 42.9	1.50 38.1	12.00 305	12.00 305	20.69 526	20.75 527	16.00 ⁽⁵⁾ 406	16.00 ⁽⁵⁾ 406	7.25 184	7.25 184	8.00 203	8.00 203	148 ⁽⁶⁾ 67	148 67	60	47
4 ⁽⁴⁾ 100	1.688 42.9	1.50 38.1	12.00 305	12.00 305	20.69 526	20.75 527	16.00 ⁽⁵⁾ 406	16.00 ⁽⁵⁾ 406	7.25 184	7.25 184	8.00 203	8.00 203	148 67	148 67	60	47

(1) 1-piece body valve design.

(2) Valves with butt weld end connection in Classes 1690 and 2680, refer to NPS 2 (DN 50) design.

(3) 2-piece body valve design in Class 4500. 2-piece body valve design in Classes 1690 and 2680 with socket weld and threaded end connection.

(4) 2-piece body valve design

(5) Impactor handle.

(6) For 1-piece design, with butt weld end connection in Classes 1690 and 2680, weight 110 lbs (50 kg)

ASME CLASS	FIGURE NUMBERS ⁽⁷⁾		
	Stop valve	Stop check valve	Needle valve
1690	8076Z	8086Z	8096Z
2680	9076Z	9086Z	9096Z
4500	5076Z	5086Z	5096Z

(7) Threaded, socket weld or butt weld connections

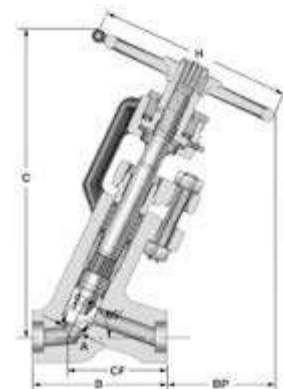

NOTE: Valves also supplied with impactor handle, electric, pneumatic or gear actuators.

VELAN FORGED STEEL PISTON CHECK VALVES

FOR HORIZONTAL AND VERTICAL LINES
 THREADED, SOCKET WELD OR BUTT WELD
 NPS ¼–4 (DN 8–100), ASME CLASSES 1690, 2680, 4500

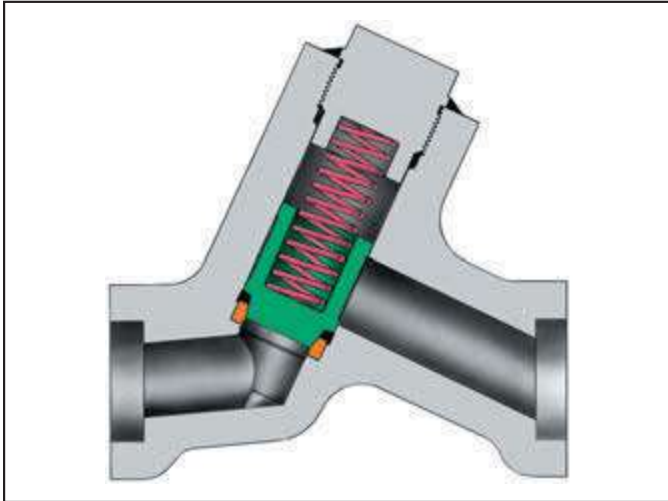

FEATURES:

- Solid CoCr alloy disc, fully guided for fast and full seating, even without spring
- High C_v
- Self-draining waterways

Part	Materials		
Body	A105N	A 182 Gr. F22	A 182 Gr. F316
Cover	A105N	A 182 Gr. F22	A 182 Gr. F316
Disc	CoCr alloy		
Seat, integral	CoCr alloy		
Spring	Gr. 302 (stainless)		

NOTE:
 Other materials available upon application.

ASME CLASS	FIGURE NUMBERS
1690	8036W
2680	9036W
4500	5036W

DIMENSIONS, WEIGHTS AND CV

Size NPS DN	Port opening		End-to-end		Center-to-top		Socket weld bore	Socket weld depth	Approximate weight lb/kg		C _v Flow coefficient	
	1690 & 2680	4500	1690 & 2680	4500	1690 & 2680	4500			1690 & 2680	4500	1690 & 2680	4500
¼	0.559	–	4.88	–	3.61	–	0.555	0.375	6.5	–	1.0	–
8	14.2	–	124	–	92	–	14.1	9.5	3.0	–	1.0	–
¾	0.559	0.375	4.88	5.75	3.61	4.26	0.690	0.375	6.3	5	1.8	1.5
10	14.2	9.5	124	146	92	108	17.5	9.5	2.9	2.3	1.8	1.5
½	0.559	0.559	4.88	7.00	3.61	5.5	0.855	0.375	6.1	25	2.1	2.1
15	14.2	14.2	124	178	92	140	21.7	9.5	3	11	2.1	2.1
¾	0.559	0.559	4.88	7.00	3.61	5.5	1.065	0.500	5.7	25	4.3	4.3
20	14.2	14.2	124	178	92	140	27.1	12.7	2.6	11	4.3	4.3
1	0.833	0.559	5.75	7.00	4.75	5.5	1.330	0.500	10	25	8.4	4.3
25	21.2	14.2	146	178	121	140	33.8	12.7	4.5	11	8.4	4.3
1¼	1.125	–	7.25	–	5.88	–	1.675	0.500	18.5	–	17	–
32	28.6	–	184	–	150	–	42.5	12.7	8.4	–	17	–
1½	1.125	1.125	7.25	10.13	5.88	6.88	1.915	0.500	18.5	42	19	18
40	28.6	28.6	184	257	150	175	48.6	12.7	8.4	19	19	18
2	1.688	1.50	10.13	12.00	7.19	8.44	2.406	0.625	36	87	45	36
50	42.9	38.1	257	305	183	214	61.1	15.9	16.3	40	45	36
2½ ⁽¹⁾	1.688	1.50	12.00	12.00	8.06	8.44	2.906	0.625	94	110 ⁽³⁾	45	36
65	42.9	38.1	305	305	205	214	73.8	15.9	43	50	45	36
3 ⁽¹⁾	1.688	1.50	12.00	12.00	8.06	8.44	3.535	0.625	94	110 ⁽³⁾	45	36
80	42.9	38.1	305	305	205	214	89.8	15.9	43	50	45	36
4	1.688	1.50	12.00	12.00	8.06	8.44	(2)	(2)	94	110	45	36
100	42.9	38.1	305	305	205	214	(2)	(2)	43	50	45	36

(1) For Classes 1690 and 2680, dimensions are as shown, or same as for NPS 2 (DN 50) valve, depending on end connection.

(2) NPS 4 (DN 100) butt weld or flanged connection only.

(3) For butt weld weight is 40 lbs. (18 kg).

PRESSURE-TEMPERATURE RATINGS (°F)

Forged socket weld, threaded, butt weld, and combination ends valves

Forged ASTM material standard – to ASME B16.34

ASME Boiler and Pressure Vessel Code Section II materials that also meet the requirements of the listed ASTM specifications – psig/°F, Classes 1690–4500.

FORGED CARBON STEEL A105⁽¹⁾

Working pressure by Classes, psig

CLASS	1690			2680			4500												
	Shell	Seat	Temp	Shell	Seat	Temp	Shell	Seat	Temp										
	6275	4600	°F	6350	4650	°F	9925	7300	°F	10050	7375	°F	16675	12225	°F	16875	12375	°F	
	Standard	Special	Limited	Standard	Special	Limited	Standard	Special	Limited	Standard	Special	Limited	Standard	Special	Limited	Standard	Special	Limited	
-20 to 100	4175	4225	4225	6615	6700	6700	11110	11250	11250	200	3825	4225	4225	6065	6700	6700	10185	11250	11250
300	3685	4170	4170	5845	6615	6615	9815	11105	11105	400	3570	4130	4130	5660	6545	6545	9505	10995	10995
500	3395	4130	4130	5385	6545	6545	9040	10995	10995	600	3200	4130	4130	5070	6545	6545	8515	10995	10995
650	3095	4030	4030	4905	6390	6390	8240	10730	10730	700	3000	3895	3895	4745	6175	6175	7960	10365	10365
750	2855	3570	3570	4535	5665	5665	7610	9515	9515	800	2315	2895	2895	3675	4595	4595	6170	7715	7715
850	1795	2245	2245	2845	3560	3560	4785	5980	5980										

FORGED CHROME-MOLY STEEL A182 Gr. F22⁽²⁾

Working pressure by Classes, psig

CLASS	1690			2680			4500		
	Shell	Seat	Temp	Shell	Seat	Temp	Shell	Seat	Temp
	6350	4650	°F	10050	7375	°F	16875	12375	°F
	Standard	Special	Limited	Standard	Special	Limited	Standard	Special	Limited
-20 to 100	4225	4225	4225	6700	6700	6700	11250	11250	11250
200	4225	4225	4225	6700	6700	6700	11250	11250	11250
300	4100	4165	4165	6505	6605	6605	10925	11090	11090
400	3975	4100	4100	6305	6500	6500	10585	10915	10915
500	3745	4080	4080	5940	6470	6470	9965	10865	10865
600	3410	4060	4060	5405	6445	6445	9070	10815	10815
650	3315	4035	4035	5260	6395	6395	8825	10735	10735
700	3200	3985	3985	5070	6320	6320	8515	10605	10605
750	2995	3985	3985	4750	6320	6320	7970	10605	10605
800	2860	3985	3985	4535	6320	6320	7610	10605	10605
850	2745	3815	3815	4350	6050	6050	7305	10160	10160
900	2530	3380	3380	4015	5360	5360	6740	9000	9000
950	2175	2660	2725	3450	4215	4385	5795	7070	7555
1000	1505	1880	2025	2390	2985	3370	4010	5015	6215
1050	985	1235	1330	1560	1950	2205	2625	3280	4065
1100	620	770	830	980	1225	1385	1645	2055	2545

SELECTION RULES :

- A) These tables do not apply to flanged valves. Consult Velan's Small Forged Valves catalog (CAT-SFV) for flanged-end valve ratings.
- B) Butt weld valves may be designated as Standard Class and Special Class, or Limited Class NPS 2½ (DN 65) and smaller.
- C) Socket weld valves are limited to NPS 2½ (DN 65) and smaller and may be designated as Standard Class, Special Class, or Limited Class.
- D) Threaded-end or combination threaded-end valves are limited to NPS 2½ (DN 65) and smaller and may be designated as Standard Class, Special Class, or Limited Class, up to 2500 Class (not shown). The ratings terminate at 1000°F (538°C).
- E) Special Class: Requires additional inspection per ASME B16.34, para. 2.1.3.

FORGED STAINLESS STEEL A182 Gr. F316⁽³⁾

Working pressure by Classes, psig

CLASS	1690			2680			4500												
	Shell	Seat	Temp	Shell	Seat	Temp	Shell	Seat	Temp										
	6100	4475	°F	6350	4650	°F	9650	7075	°F	10050	7375	°F	16200	11900	°F	16875	12375	°F	
	Standard	Special	Limited	Standard	Special	Limited	Standard	Special	Limited	Standard	Special	Limited	Standard	Special	Limited	Standard	Special	Limited	
-20 to 100	4055	4225	4225	6430	6700	6700	10800	11250	11250	200	3485	3895	3895	5530	6175	6175	9290	10365	10365
300	3150	3515	3515	4995	5575	5575	8390	9360	9360	400	2895	3230	3230	4590	5120	5120	7705	8600	8600
500	2690	3005	3005	4265	4760	4760	7165	7995	7995	600	2540	2840	2840	4030	4495	4495	6770	7555	7555
650	2490	2775	2775	3945	4400	4400	6625	7395	7395	700	2445	2730	2730	3880	4330	4330	6515	7270	7270
750	2405	2685	2685	3815	4260	4260	6410	7150	7150	800	2380	2655	2655	3775	4215	4215	6335	7070	7070
850	2355	2625	2625	3730	4165	4165	6265	6990	6990	900	2340	2610	2610	3710	4140	4140	6230	6950	6950
950	2175	2580	2580	3450	4090	4090	5795	6870	6870	1000	2050	2370	2370	3250	3755	3755	5450	6310	6310
1050	2030	2370	2370	3215	3755	3755	5400	6310	6310	1100	1720	2145	2200	2730	3410	3545	4575	5720	6115
1150	1335	1665	1795	2110	2640	2985	3550	4435	5495	1200	1045	1300	1400	1655	2070	2340	2775	3470	4300
1250	830	1035	1115	1320	1645	1860	2210	2765	3425										













FORGED CHROME-MOLY STEEL A182 Gr. F91

Working pressure by Classes, psig

CLASS	1690			2680			4500		
	Shell	Seat	Temp	Shell	Seat	Temp	Shell	Seat	Temp
	6350	4650	°F	10050	7375	°F	16875	12375	°F
	Standard	Special	Limited	Standard	Special	Limited	Standard	Special	Limited
-10 to 200	4225	4225	4225	6700	6700	6700	11250	11250	11250
200	4225	4225	4225	6700	6700	6700	11250	11250	11250
300	4100	4225	4225	6505	6700	6700	10925	11250	11250
400	3975	4225	4225	6305	6700	6700	10585	11250	11250
500	3745	4225	4225	5940	6700	6700	9965	11250	11250
600	3410	4225	4225	5405	6700	6700	9070	11250	11250
650	3315	4225	4225	5260	6700	6700	8825	11250	11250
700	3200	4130	4130	5070	6550	6550	8515	10995	10995
750	2995	4105	4105	4750	6505	6505	7970	10930	10930
800	2860	4055	4055	4535	6430	6430	7610	10800	10800
850	2745	3815	3815	4350	6050	6050	7305	10160	10160
900	2530	3380	3380	4015	5360	5360	6740	9000	9000
950	2175	2660	2725	3450	4215	4385	5795	7070	7555
1000	2050	2370	2555	3250	3755	4240	5450	6310	7820
1050	2030	2370	2555	3215	3755	4240	5400	6310	7820
1100	1700	2125	2290	2695	3370	3805	4525	5655	7005
1150	1255	1570	1695	1990	2485	2805	3345	4180	5180
1200	810	1015	1095	1285	1610	1820	2160	2700	3345

- (1) Permissible but not recommended for prolonged usage above 800°F (425°C).
- (2) Permissible but not recommended for prolonged usage above 1100°F (593°C).
- (3) At temperatures over 1000°F (538°C) use only when the carbon content is 0.04% or higher (material code 10).

HOW TO ORDER

Type of connection	Size of connection	Pressure rating	Valve type	Body/bonnet style	Body material	Trim Material
A 	B  	C 	D  	E  	F  	G  
S	0 4	— 8	0 7	6 Z	— 0 2	T S

Example: NPS 3/4 (DN 20) threaded CS bonnetless stop globe valve with TS trim (see below).

The figure numbers shown on this key are designed to cover essential features of Velan valves. Please use figure numbers to ensure prompt and accurate processing of your order. A detailed description must accompany any special orders.

For live-loading and leak-off options, add a one-digit suffix to the figure number:
 0 - for live-loading, double packing and leak-off;
 2 - for live-loading only;
 3 - for double packing and leak-off only.

Example: W05-8076Z-02TS-2 is a: NPS 1 (DN 25) Class 1690 carbon steel Y-pattern stop globe valve with TS trim and live-loading.

A	TYPE OF CONNECTION	
B	Butt weld	S Thread NPT
C	Combination (socket weld/threaded)	W Socket weld
F	Flanged B16.5 (B16.47 series A)	

B	SIZE OF CONNECTION				
Customers have the choice of specifying valve size as part of the valve figure number (B) using the numbers below, or indicating valve size separately. Sizes shown in NPS (DN)					
EXAMPLES: B16-3054P-02TS (valve size is part of figure number) NPS 10 B-3054P-02TS (valve size is shown separately)					
01	¼ (8)	05	1 (25)	08	2 (50)
03	½ (15)	06	1½ (32)	09	2½ (65)
04	¾ (20)	07	1½ (40)	10	3 (80)
				12	4 (100)

C	PRESSURE RATING				
2	600	4	2500	7	900
3	1500	5	4500	8	1690

D	VALVE TYPE		
01	Flow control	07	Stop globe
03	Piston check	08	Stop check
		09	Needle

E	BODY/BONNET STYLE	
6	Inclined y-pattern	S Y-pattern bellows seal (non-rotating stem)
7	Inclined y-pattern bonnetless 45°	W Welded bonnet
		Z Bonnetless (non-rotating stem)

Note: Velan valves for **NACE** service (as indicated by figure number and/or description) comply with the metallurgical requirements of the current NACE MR0103 and MR0175 / ISO 15156. Material selection is dependent on the actual environment and it is therefore the equipment End User's responsibility to ensure that the materials are suitable for the intended service. Please contact Velan for any questions regarding the application of our products for NACE service.

F	BODY MATERIAL ⁽¹⁾				
02	A105	13	S/S F316 ⁽³⁾	27	LF3/LC3
06	CHR. MOLY F22	14	S/S F316L	34	F91
10	S/S F316H ⁽²⁾	15	S/S F347		

G	TRIM MATERIAL (standard trims)				
Code	Wedge/disc surface ⁽⁴⁾	Seat surface ⁽⁴⁾	Stem	Bellows ⁽⁵⁾	
MS	Standard	CoCr alloy ⁽⁶⁾	CoCr alloy ⁽⁶⁾	316/316L	321
TS		CoCr alloy ⁽⁶⁾	CoCr alloy ⁽⁶⁾	13 CR (410)	321
NE	Nace Service ⁽⁷⁾	CoCr alloy ⁽⁶⁾	CoCr alloy ⁽⁶⁾	13 CR 410 HRC 22 max.	Inconel 625
NG		CoCr alloy ⁽⁶⁾	CoCr alloy ⁽⁶⁾	316/316L	321
ES	CoCr alloy ⁽⁶⁾	CoCr alloy ⁽⁶⁾	347	—	
US	CoCr alloy ⁽⁶⁾	CoCr alloy ⁽⁶⁾	S/S 616 HT	—	

- (1) Other materials are available upon request.
- (2) Material code "10" F316H/F316 has a minimum carbon content of 0.04 and is to be used if temperatures are over 1000°F (538°C).
- (3) Material code "13" Forged F316 is not suitable for temperatures above 1000°F (538°C) as it is dual certified (F316/F316L).
- (4) Base material is either the same as the body or solid trim at manufacturer's option.
- (5) Bellows material shown as standard, inconel can be used in lieu of SS 321 and Hastelloy in lieu of Inconel, where design and/or pressure class applicable.
- (6) CoCr alloy (Grade 6 or 21) based on material or application at manufacturer's option.
- (7) NACE service valves are supplied with bolting with max. hardness of RC22.

Note: CoCr alloy as used throughout this catalog refers to cobalt chrome hardfacing alloys as supplied by Kennametal Stellite™, and other approved manufacturers.

The most comprehensive line of industrial forged and cast steel gate, globe, check, ball, butterfly, and knife gate valves and steam traps.

ASME pressure classes 150–4500 in carbon, alloy, and stainless steel

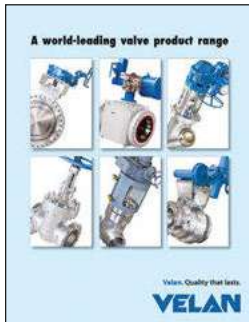

BRO-FLB

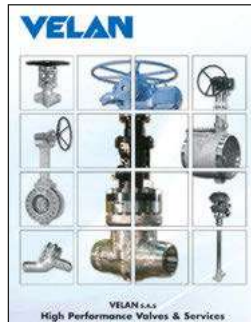

SAS-FLB

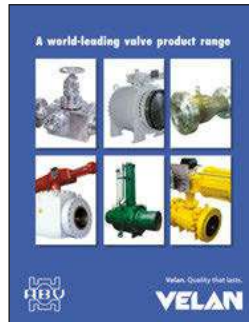

ABV-FLB

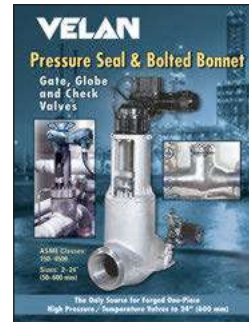

VEL-PS

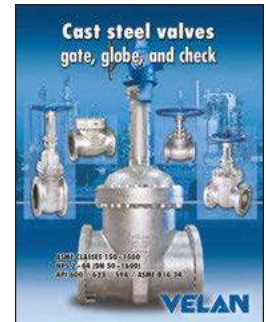

CAT-CSV

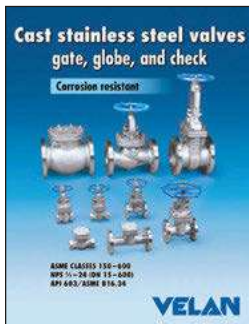

CAT-CSSV

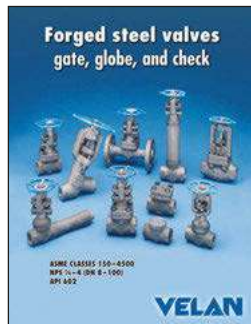

CAT-SFV

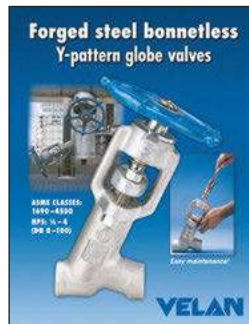

CAT-BG

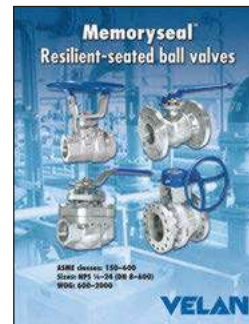

CAT-BV

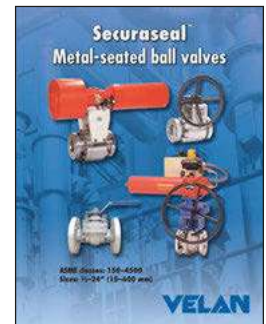

VEL-MS

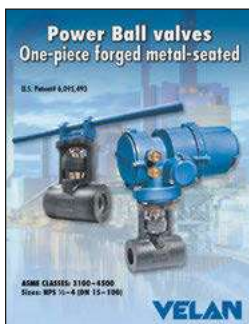

CAT-PBV

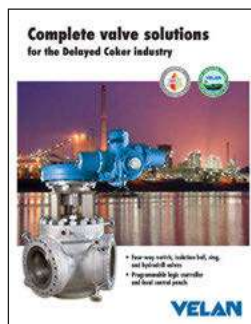

BRO-CBV

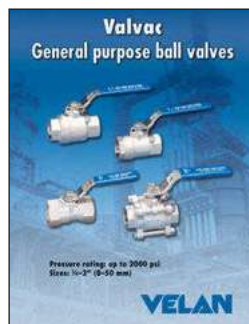

CAT-GPBV

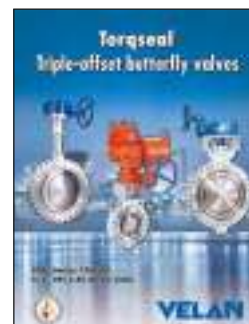

CAT-BF

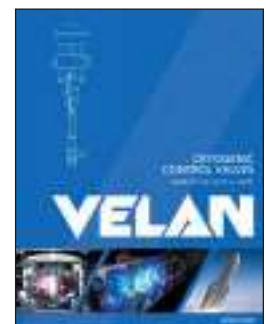

SAS-CCV

⚠ WARNING: The use of chainwheels may present a risk of serious injury to personnel or damage to property if the chainwheel becomes detached and falls. The end user and purchaser shall be responsible to ensure the correct installation, operation, maintenance and safety provisions related to chainwheels. Velan does not assume any liability whatsoever for the safe application and operation of chainwheels supplied by parties other than Velan or for chainwheels that are used without a suitably designed safety device.

Headquartered in Montreal, Canada, Velan has several international subsidiaries. For general inquiries:

Velan head office

7007 Côte de Liesse, Montreal, QC H4T 1G2 Canada

Tel: +1 514 748 7743 Fax: +1 514 748 8635

Check our website for more specific contact information.

www.velan.com

CAT-BG-12-14c

Printed in Canada

© 2019 Velan Inc., Montreal, QC, Canada. All rights reserved. The contents hereof are confidential and proprietary to Velan. Any unauthorized reproduction or disclosure, in whole or in part, is strictly prohibited. The material in this catalog is for general information only and shall not be used for specific performance data and material selection without first consulting Velan. Velan reserves the right to change this information without notice. Velan does not accept any liability or damages arising from the use of information in this catalog. Velan, Velan Ultraflex, Steamless, Moss, Torqseal, Memoryseal, Securaseal, Velflex, Rama, Clama, Adareg, and Rama Clama II are trademarks or registered trademarks of Velan Inc. and/or another Velan company. One or more of these trademarks are registered in certain countries/regions, please contact Velan Inc.'s legal department for further information. All other trademarks and registered trademarks are owned by their respective companies.

